

EXPERIMENT MANUAL

ROBOTICS

SMART MACHINES

HOVERBOTS

with BalanceTech



 THAMES & KOSMOS

Franckh-Kosmos Verlags-GmbH & Co. KG, Pfizerstr. 5-7, 70184 Stuttgart, Germany | +49 (0) 711 2191-0 | www.kosmos.de
Thames & Kosmos, 89 Ship St., Providence, RI, 02903, USA | 1-800-587-2872 | www.thamesandkosmos.com
Thames & Kosmos UK LP, 20 Stone Street, Cranbrook, Kent, TN17 3HE, UK | 01580 713000 | www.thamesandkosmos.co.uk

Safety Information

WARNING. Only for use by children aged 8 years and older. Instructions for parents or other supervising adults are included and have to be observed. Keep packaging and instructions as they contain important information.

WARNING. Not suitable for children under 3 years. Choking hazard — small parts may be swallowed or inhaled. Store the experiment material and assembled models out of the reach of small children.

Safety for Experiments with Batteries

>>> To operate the models, you will need 6 AA batteries (1.5-volt, type AA/LR6) or 6 AA rechargeable batteries (1.2-volt, type AA, HR6/KR6), which could not be included in the kit due to their limited shelf life.

>>> The supply terminals are not to be short-circuited. A short circuit can cause the wires to overheat and the batteries to explode.

>>> Different types of batteries or new and used batteries are not to be mixed.

>>> Do not mix old and new batteries.

>>> Do not mix alkaline, standard (carbon-zinc), or rechargeable (nickel-cadmium) batteries.

>>> Batteries are to be inserted with the correct polarity. Press them gently into the battery compartment. See page 8.

>>> Always close battery compartments with the lid.

>>> Non-rechargeable batteries are not to be recharged. They could explode!

>>> Rechargeable batteries are only to be charged under adult supervision.

>>> Rechargeable batteries are to be removed from the toy before being charged.

>>> Exhausted batteries are to be removed from the toy.

>>> Dispose of used batteries in accordance with environmental provisions, not in the household trash.

>>> Be sure not to bring batteries into contact with coins, keys, or other metal objects.

>>> Avoid deforming the batteries.

As all of the experiments use batteries, have an adult check the experiments or models before use to make sure they are assembled properly. Always operate the motorized models under adult supervision.

After you are done experimenting, remove the batteries from the battery compartments. Note the safety information accompanying the individual experiments or models!

Notes on Disposal of Electrical and Electronic Components

The electronic components of this product are recyclable. For the sake of the environment, do not throw them into the household trash at the end of their lifespan. They must be delivered to a collection location for electronic waste, as indicated by the following symbol:



Please contact your local authorities for the appropriate disposal location.

Dear Parents,

Before starting the experiments, read through the instruction manual together with your child and discuss the safety information. Check to make sure the models have been assembled correctly, and assist your child with the experiments. **We hope you and your child have a lot of fun with the experiments!**

FCC Part 15 Statement

This device complies with Part 15 of the FCC Rules. Operation is subject to the following two conditions: (1) this device may not cause harmful interference, and (2) this device must accept any interference received, including interference that may cause undesired operation.

Warning: Changes or modifications not expressly approved by the party responsible for compliance could void the user's authority to operate the equipment.

NOTE: This equipment has been tested and found to comply with the limits for a Class B digital device, pursuant to Part 15 of the FCC Rules. These limits are designed to provide reasonable protection against harmful interference in a residential installation. This equipment generates, uses and can radiate radio frequency energy and, if not installed and used in accordance with the instructions, may cause harmful interference to radio communications. However, there is no guarantee that interference will not occur in a particular installation. If this equipment does cause harmful interference to radio or television reception, which can be determined by turning the equipment off and on, the user is encouraged to try to correct the interference by one or more of the following measures:

- Reorient or relocate the receiving antenna.
- Increase the separation between the equipment and receiver.
- Connect the equipment into an outlet on a circuit different from that to which the receiver is connected.
- Consult the dealer or an experienced radio/TV technician for help.

FCC RF Exposure Statement

To comply with the FCC RF exposure compliance requirements, this device and its antenna must not be co-located or operating in conjunction with any other antenna or transmitter.

For body worn operation, this device has been tested and meets FCC RF exposure guidelines when used with an accessory that contains no metal and that positions the device a minimum of 5 mm from the body. Use of other accessories may not ensure compliance with FCC RF exposure guidelines.

Simplified EU Declaration of Conformity

Thames & Kosmos hereby declares that the radio communication unit "Robotics Smart Machines" balancing robotic base unit, model number 7433-W85-A-US, conforms to Directive 2014/53/EU. The complete text of the EU conformity declaration is available at the following Internet address: <http://thamesandkosmos.com/rsmhoverbots/declaration.pdf>



>>> KIT CONTENTS

GOOD TO KNOW! If you are missing any parts, please contact Thames & Kosmos customer service.
 US: techsupport@thamesandkosmos.com
 UK: techsupport@thamesandkosmos.co.uk

What's inside your experiment kit:



You will also need:

- 6 AA batteries (1.5-volt, type AA/LR6) or 6 AA rechargeable batteries (1.2-volt, type AA, HR6/KR6), a small Phillips-head screwdriver to open the battery compartment, and a tablet or smartphone running iOS or Android (see page 7 for app information)

Checklist: Find – Inspect – Check off

✓	No.	Description	Qty.	Item No.
<input type="checkbox"/>	1	Short anchor pin, yellow	30	7344-W10-C2Y
<input type="checkbox"/>	2	Anchor pin, gray	30	7061-W10-C1S
<input type="checkbox"/>	3	Fixed joint pin, magenta	18	1187-W10-E1K
<input type="checkbox"/>	4	Joint pin, blue	16	7413-W10-T1B
<input type="checkbox"/>	5	Long join pin, gray	12	7413-W10-U1S
<input type="checkbox"/>	6	Two-to-one converter, white	1	7061-W10-G1W
<input type="checkbox"/>	7	90-degree converter X	3	7061-W10-X1Y
<input type="checkbox"/>	8	90-degree converter Y	2	7061-W10-Y1B1
<input type="checkbox"/>	9	1-hole connector	6	7430-W10-B1D
<input type="checkbox"/>	10	Rod connector, gray	2	7026-W10-L2S1
<input type="checkbox"/>	11	Rod connector, orange	1	7026-W10-L2O
<input type="checkbox"/>	12	3-hole crank, orange	1	7409-W10-H1O
<input type="checkbox"/>	13	Curved rod, gray	4	7061-W10-V1S4
<input type="checkbox"/>	14	3-hole rod, black	1	7026-W10-Q2D
<input type="checkbox"/>	15	3-hole dual rod, yellow	5	7413-W10-Y1Y2
<input type="checkbox"/>	16	5-hole rod, yellow	6	7413-W10-K2Y
<input type="checkbox"/>	17	5-hole cross rod, black	1	7413-W10-R1D
<input type="checkbox"/>	18	5-hole dual rod C, blue	2	7413-W10-X1B
<input type="checkbox"/>	19	5-hole dual rod B, gray	4	7413-W10-W1S3
<input type="checkbox"/>	20	3-hole wide rounded rod, black	6	7404-W10-C1D
<input type="checkbox"/>	21	7-hole wide rounded rod, black	6	7404-W10-C2D
<input type="checkbox"/>	22	7-hole flat rounded rod, black	6	7404-W10-C3D
<input type="checkbox"/>	23	9-hole rod, blue	6	7407-W10-C1B1
<input type="checkbox"/>	24	11-hole rod, black	6	7413-W10-P1D

✓	No.	Description	Qty.	Item No.
<input type="checkbox"/>	25	5-hole flexible rod, white	2	7432-W10-A1W
<input type="checkbox"/>	26	7-hole flexible rod, white	2	7432-W10-A2W
<input type="checkbox"/>	27	5x5 square frame, gray	5	7413-W10-Q1S3
<input type="checkbox"/>	28	5x10 frame, gray	2	7413-W10-I1S2
<input type="checkbox"/>	29	3x13 dual frame, gray	2	7406-W10-A1S1
<input type="checkbox"/>	30	3-hole rounded dual rod with pegs	1	7404-W10-B1B
<input type="checkbox"/>	31	Diagonal connector, blue	4	7404-W10-B2B
<input type="checkbox"/>	32	Main body piece, blue	1	7445-W10-C1B1
<input type="checkbox"/>	33	Large body piece, yellow	2	7446-W10-A1Y1
<input type="checkbox"/>	34	Small body piece, right	2	7446-W10-A3Y1
<input type="checkbox"/>	35	Small body piece, left	2	7446-A10-A2Y1
<input type="checkbox"/>	36	Hexagonal body plate 2	6	7427-W10-F1Y
<input type="checkbox"/>	37	Hexagonal body plate 1	2	7427-W10-F2Y
<input type="checkbox"/>	38	30-mm axle, black	4	7413-W10-N1D
<input type="checkbox"/>	39	100-mm axle, black	2	7413-W10-L2D
<input type="checkbox"/>	40	Small gear, gray	2	7026-W10-D2S
<input type="checkbox"/>	41	Large wheel frame, black	2	7444-W10-A1D
<input type="checkbox"/>	42	Racing tire, gray	2	1115-W85-F2S
<input type="checkbox"/>	43	Large tire	2	7408-W10-C1D
<input type="checkbox"/>	44	Wheel, blue	2	7407-W10-B1B
<input type="checkbox"/>	45	Anchor pin lever	1	7061-W10-B1Y
<input type="checkbox"/>	46	Balancing robotic base unit	1	7433-W85-A-US
<input type="checkbox"/>	47	Decorative decal sheet	1	R20#7433-US-1

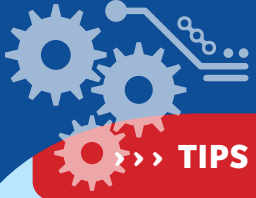

>> TIPS AND TRICKS

Here are a few tips for assembling and using the models. Read them carefully before starting.

A. The anchor pin lever

In the box, you will find a little yellow tool called the anchor pin lever. End A of the part separator tool makes it easy to remove anchor pins from the frames. You can use the wide end to pry up other parts.

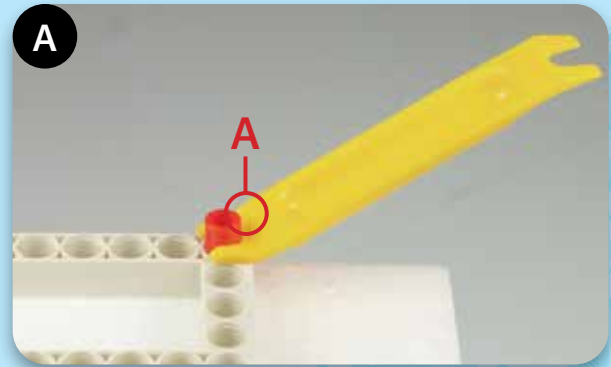

B. Anchor pins and other connectors

Take a careful look at the different assembly components. Yellow anchor pins, gray anchor pins, magenta joint pins, blue joint pins, and gray joint pins may all look pretty similar at first glance. When you assemble the models, it's important to use the right ones. The yellow anchor pins are shorter than the gray ones.

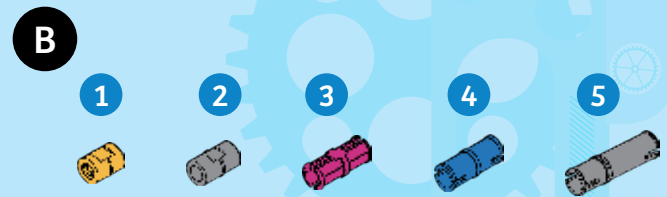

C. Connecting frames and rods

Use the anchor pins to connect frames and rods. Pay close attention to the instructions showing exactly which holes should be used in a particular step. The red and green lines in the assembly diagrams show which holes to use.

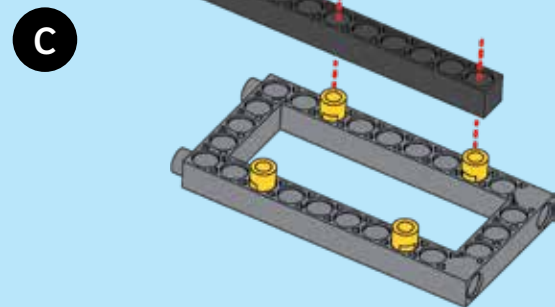

D. Axles

The building system contains axles (also called shafts) of various lengths. When assembling the model, always be sure that you're using the right one.

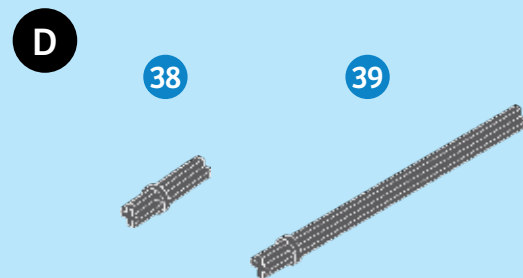

>>> TABLE OF CONTENTS



TIP!

Above each set of assembly instructions, you will find a red bar:

>>> It shows you the difficulty level for the model's assembly:



Safety Information Inside front cover

Kit Contents..... 1
Tips and Tricks 2
Table of Contents..... 3

Robots with a Sense of Balance

Getting Started 5
About BalanceTech..... 6
Downloading and Installing the App 7
Building the Test Robot 8

Control App Information

Remote Control Mode..... 10
Balance Settings 11
Programming Mode 12

The Models:

HoverBot and Rover..... 16
Programming the HoverBot in Rover Mode.....22

Transform Rover into HoverBot24
Programming the HoverBot25

Pendulum27
Programming the Pendulum.....29

Balancing Bird.....31
Programming the Balancing Bird.....35

Robotic Waiter37
Programming the Robotic Waiter41

Target Practice Robot.....43
Programming the Target Practice Robot47

Balancing Dino Robot49
Programming the Balancing Dino Robot53

Personal Transporter.....55
Programming the Personal Transporter.....59

Publisher's InformationInside back cover

TWO APPS:

1. CONTROL APP

2. DIGITAL ASSEMBLY INSTRUCTIONS APP

There are two free apps that accompany this product. The control app is used to remotely control and program your robots. A second app with 3D digital assembly instructions is available in addition to this manual. This app guides you step by step through building each model.

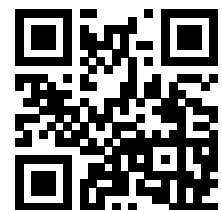

Scan this QR code to open the product web page. Then, follow the links to access the two apps in the app stores. Available for iOS and Android.



Robots with a Sense of Balance

Robots are mechanical agents controlled by computer programs. They can be programmed to perform all sorts of tasks and movements. Robots can assemble cars, play soccer, vacuum floors, deliver packages, map terrain, climb mountains, entertain people, cook dinner — the list goes on and on. Keeping robots balanced so that they can perform their tasks is a challenge many robotics engineers must tackle. With this kit, you can build robots that use a combination of sensors to keep themselves balanced upright and to drive around on two wheels. With the control app, you can program the robots you build to move around, light up, and make sounds. You can also experiment with the balance settings to learn how this technology works.

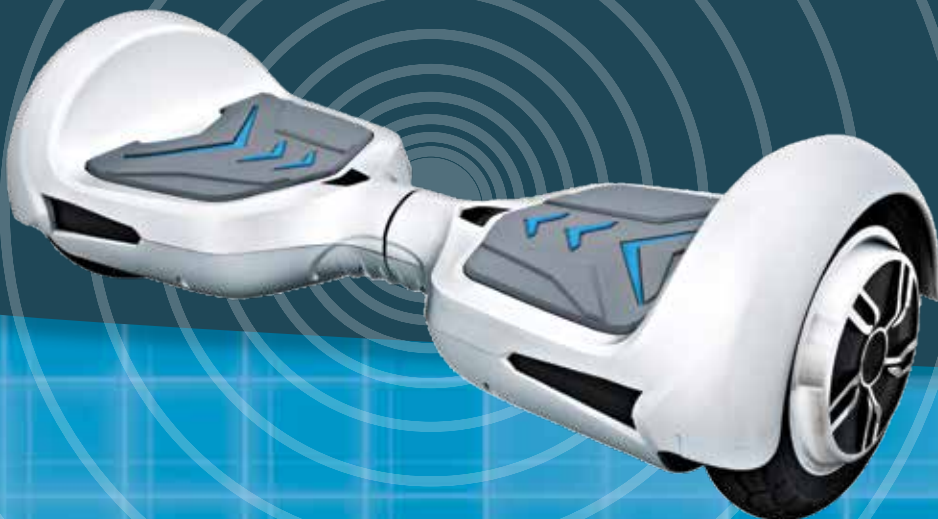

GETTING STARTED

There are three primary types of functional components to this kit that enable the robots to work:

A. The balancing robotic base unit is the platform for all of your balancing robot creations. This robotic device contains a number of key functional components itself, including ...

... **a microcontroller**, which is essentially a small computer. This is the “brain” of your robot. It takes sensor data and instructions from the app.

... **a gyroscope sensor**, which senses the robot’s position and angle of tilt.

... **an acceleration sensor**, which senses the robot’s change in speed.

... **two motors with encoders**, which connect to the wheels and axles to move the robot around and tell the microcontroller how fast the robot is moving.

... **a Bluetooth wireless module**, which allows the base unit to connect to the app on your tablet or smartphone.

... **a battery compartment**, which provides power to all the electrical components.

B. The wheels and axles connect to the motors inside the robotic base use and allow the models to drive around.

C. The app allows you to remotely control and program the robots you build.

These three elements, in combination with all the mechanical parts — rods, gears, axles, frames, and so on — allow you to build and program robots that can balance on their two wheels.

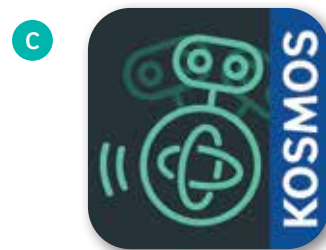
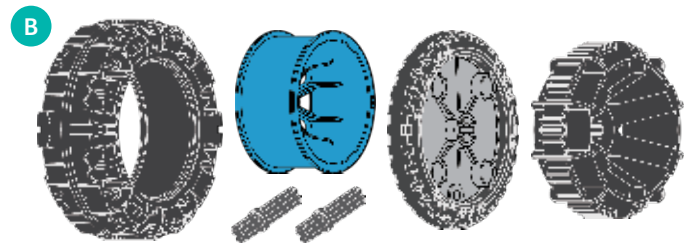
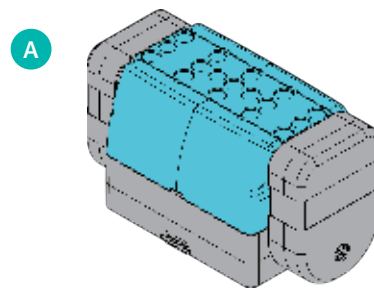

HoverBots

To get started:

1. **Download the apps** following the instructions on page 7.
2. Follow the assembly instructions on page 8 to **build the test model called Chassis 1**. (For all of the assembly instructions, you can either use this manual or the digital assembly instructions app.)
3. Follow the instructions for **testing Chassis 1** with the control app at the bottom of page 9.
4. Refer to pages 10–15 for information on how the **control app** works.
5. Now, proceed with building the **other models**, one at a time, and running the **sample programs** given on the programming page found after the assembly instructions for each model.



ABOUT THE BALANCING TECHNOLOGY

A **special technology** keeps the robot models in this kit **balanced** whether they are stationary, or moving forward or backward, or turning. The same technology is used inside hoverboards, Segways, and other personal transporters that balance on two side-by-side wheels.

This balancing behavior is achieved with **sensors** and a **microcontroller** that work together to tell the **motors** how to turn the **wheels** in order to remain balancing. A microcontroller is a computer; it functions as the “brain” of the balancing vehicle.

The wheels are the only part of this type of balancing vehicle that are touching the ground, so the balancing behavior depends on the location of the wheels relative to the vehicle’s **center of gravity** at all times. For more information about the center of gravity, see page 36. The whole system is powered by **batteries**.

There are three primary types of sensors at work in the balancing vehicles. A **gyroscope sensor** is used to detect the angle of tilt of the vehicle. An **accelerometer** is a sensor that detects the acceleration, or change in speed, of the vehicle. Together, these two sensors can tell the microcontroller if the vehicle is tilting too far forward or backward and moving too fast forward or backward to remain balanced. Then, sensors attached to the motors, called **encoders**, can determine the current speed of the wheels. The microcontroller uses the readings from the gyroscope sensor, the accelerometer, and the encoders to instruct the motors what to do. Programmers write **algorithms**, or complex sets of calculations, that run on the microcontroller. The algorithms are used to constantly analyze the sensor readings and make instant adjustments to the speed of the wheels.

If the vehicle is tipping too far forward, the wheels will speed up in that direction, so the wheels always stay underneath the center of gravity. If the vehicle is tipping too far backward, the wheels will speed up in reverse, again to keep the wheel under the center of gravity and to make sure the vehicle stays balanced upright. The vehicle does all this while at the same time allowing the motors to turn enough to move the vehicles forward or backward in space, depending on how the driver is controlling it.

Parts of the balancing robotic base unit:

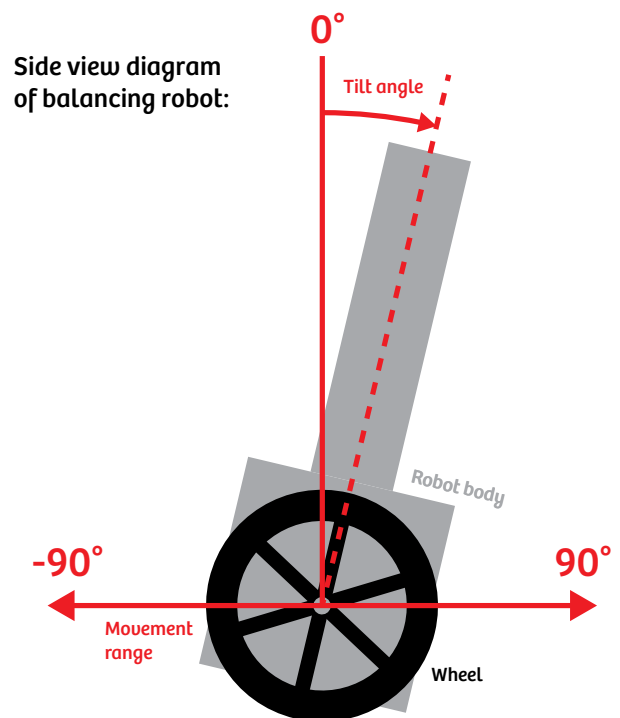
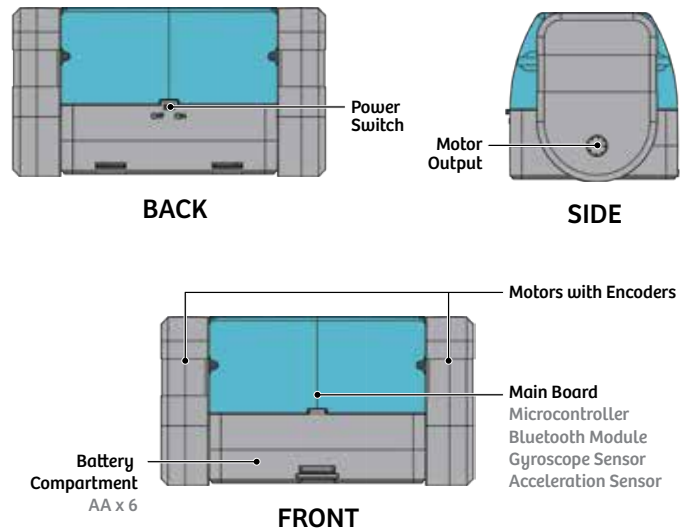

DOWNLOADING AND INSTALLING THE APPS

DOWNLOAD THE APPS

There are two apps that accompany this item. One app, called the **control app**, allows you to control, program, and adjust the balance settings of your robots. The other app provides you with **3D digital assembly instructions**. This app guides you step by step through building each model.

You can download these free apps for **iOS devices** from the **iOS App Store**, or for **Android devices** from **Google Play**.

For specific device requirements, see the app pages in the app stores.

To get the apps:

1. Turn on your tablet or smartphone.
2. If you have a QR code reader installed, you can scan the QR code to right to take you to the product page for this kit.
3. On the product page, scroll down until you see the images of the app icons and the links to the app pages in the app stores. Follow the links for the correct app store based on your device.
4. Follow the steps on the app download page to download and install the app on your device.
5. Open the apps and begin using them. For instructions on how to use the controller app and to start testing it, continue to the next page.

The digital assembly instruction app is self-explanatory. You can use it in place of the assembly steps printed in this manual.



HoverBots



HoverBots Assembly Instructions

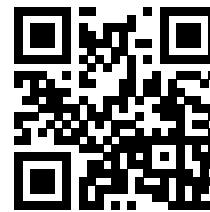

Scan this QR code to go to the product page, where there are links to download the apps from the app stores.



TEST ROBOT

BUILD THE TEST ROBOTS

First, follow these instructions to build the **balancing robot chassis** that will be the base of all the balancing robot models in this kit.

Build **chassis 1** (below) first. Use it to test out the control app, following the instructions starting on pages 9–10.

Then, you can build **chassis 2 and 3**, and test them out. How do they function compared to chassis 1? How do you need to change the balance settings to get them to work?

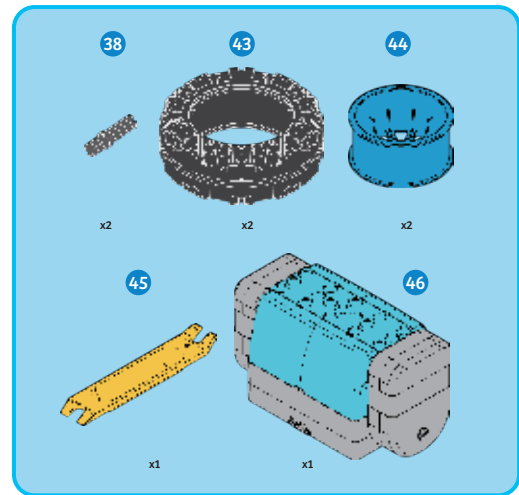

Before building anything, insert the batteries into the battery compartment of the robotic base unit.

Instructions for inserting and removing batteries:

1. With a small Phillips-head precision screwdriver, remove the screw securing the battery compartment cover shut.
2. Press the tab on the transparent battery compartment cover inward and then lift the cover off the compartment.
3. Insert or change the batteries according to the indicated plus-minus polarity markings.
4. Close the compartment by sliding the cover back on.

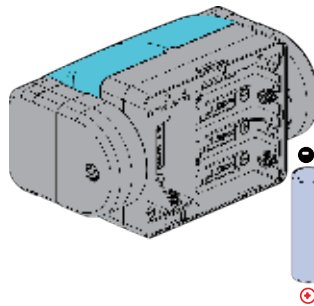

6 x AA

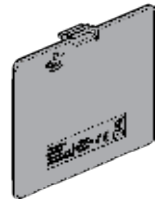
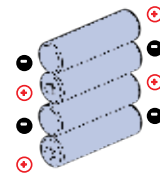

CHASSIS 1

This chassis is the base of all the other robot models in this kit.

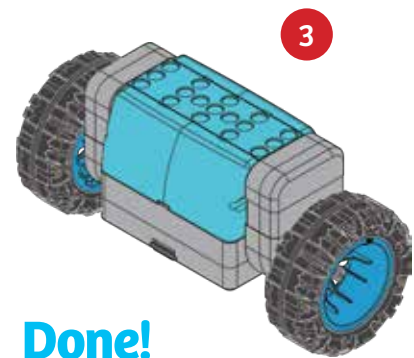
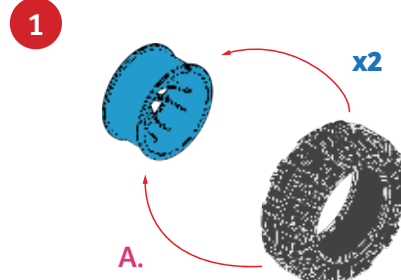
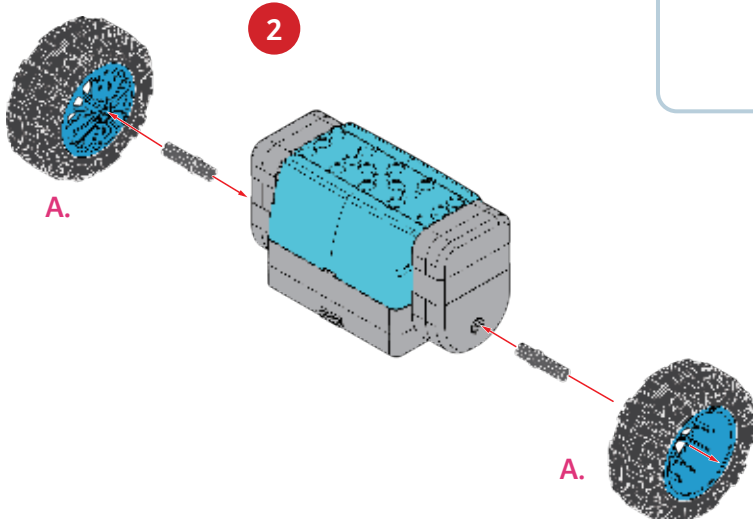

CHASSIS 2

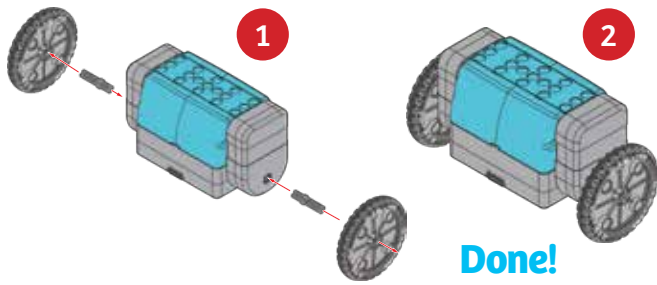

CHASSIS 3

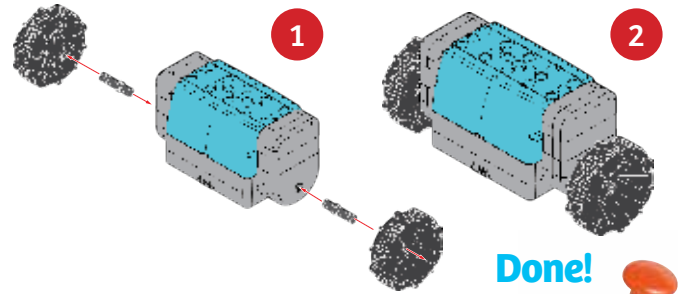

TESTING THE CHASSIS

1. Position the model with its **wheels on a smooth floor** (or large tabletop) in an open area, **holding it upright** with your hand but with **all its weight resting on the floor**, and slide the switch to the **on** position. Hold the robot upright until you feel the motors working. This helps the model balance.

Once the switch is turned on, the robot will remember and use the **last balance setting** (see page 11) that was loaded onto it. The balance setting for the test chassis is file A, which is the default setting on your robot. When you build different robot models on top of the robotic base unit, you will need to manually change the balance setting, because balance setting A might not be the correct setting to make a particular robot model balance.

Tip: If you lift the robot up off the floor, its wheels will spin as it is attempting to balance itself. **You can lay the robot on its back to stop the motors from spinning.**

2. The robot should now be balancing on its own, staying in one place and making slight adjustments so as to not fall over. If it's not balancing, try **laying it on its back** and then tilting it upright again, keeping the wheels firmly on the floor. Or try **turning it off and on again**, and trying again.
3. Open the **control app** on your device.
4. Establish a **Bluetooth connection** between the app and the robotic base unit. See the next page for more details on establishing the connection.
5. Enter **remote control mode** and experiment with using the test chassis in remote control mode. See the next page for more details.
6. Enter the **programming mode**. Tap the folder icon to open the program library. Open the test chassis program and press the run button. What does the test chassis do? See the following pages for more details on how the app works.

TROUBLESHOOTING

If you are having trouble getting the test chassis to balance and move, scan this QR code to view a video tutorial showing how to get the robot to balance.

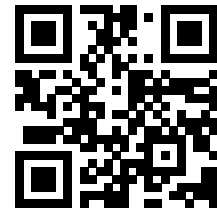

Balance Setting:

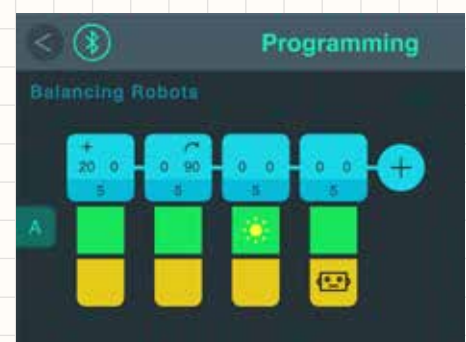

WHAT'S HAPPENING?

When the program runs, the chassis should drive forward for five seconds, then rotate to the right in place for five seconds, then light up a yellow light, and finally play the sound of a robot.



REMOTE CONTROL MODE

CONNECTING THE DEVICE

To remotely control or program the models with the app, first you must wirelessly pair the app with the balancing robotic base unit.

1. Make sure Bluetooth is turned on on your device. Open the app on your device. Tap the Bluetooth symbol.
2. Choose **HoverBots (A)** from the list of Bluetooth devices.

The app will now pair with the robotic base unit. You will then be taken to the **home screen**.

If you ever want to check or change the Bluetooth pairing, tap the **Bluetooth logo** in the upper left corner of the screen (**B**).

When the Bluetooth symbol is lit up in green, the Bluetooth connection is **active**. When the Bluetooth symbol is grayed out, it is **disconnected (C)**.

REMOTE CONTROL MODE

It's a good idea to start experimenting with your models in **remote control mode**. Here's how:

1. Tap the **remote control button (D)** on the home screen. The remote control mode screen opens.
2. By default, the **balancing I/O switch (E)** is set to I, indicating it is turned on. (The balancing technology must be turned on in order for the models to balance.)
3. The specific balance setting that is enabled is indicated by the **letter in the circle below the I/O switch (F)**. To change the setting, tap the setting letter. The balance settings page will open. Then tap the file icon to enter balance settings library. The default balance setting recommended for use with each model is given on the programming page for each model later in this manual.
4. The **control pad area (G)** allows you to move the model. Press and hold on the control pad area, and then drag your finger around the pad to move your model in any direction.
5. You can choose up to four **light and sound effects** and assign them to buttons on the remote control screen. Tap the **plus sign button (H)** and select which **effect** to assign to that button (**I**). When controlling the model, you can press these buttons to activate the effect. Press the button again to deactivate the effect.
6. Press the **reset button** to clear your effects buttons (**J**).



Tip: You can rename your HoverBot by tapping the three dots (...), entering the name, and restarting the base unit.

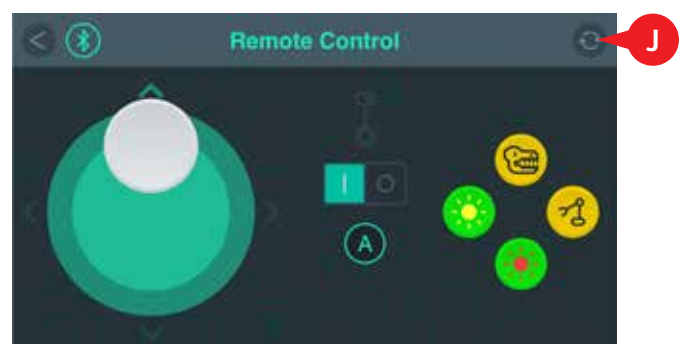
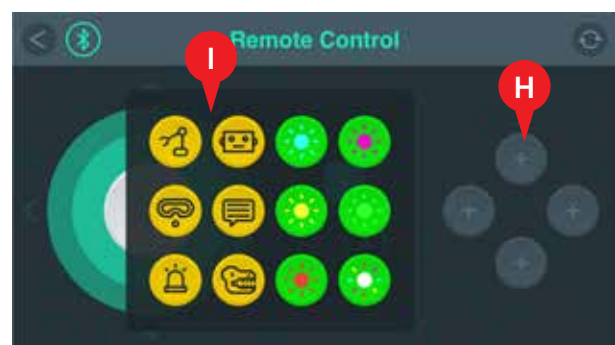
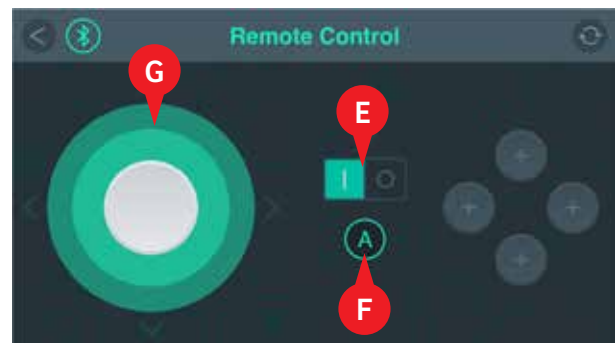

BALANCE SETTINGS

BALANCE SETTINGS

Because the different models in this kit have different shapes and weights, and therefore different centers of gravity, they require different **balance settings (A)** to keep them perfectly balanced.

There is a preset default balance setting for each model. This is indicated in this manual on the programming page at the end of the assembly instructions for each model. The preset balance settings can be edited but not saved over. You will need to choose the correct balance setting for your model whether you are using the app in remote control mode or programming mode.

You can view the saved balance settings by tapping on the **balance settings file icon (B)** and opening the **balance settings library** and then tapping on one of the **saved balance setting files (C)**.

If you design your own models, or you want to test the balance settings of one of the included models, you can define your own balance setting by tapping the dots along the side to change the page and then tapping one of the **gray balance setting records (D)**. A **balance settings screen** with five sliders will open.

After setting the **five sliders (E)** to the values that you want to try, press the **run button (F)** to load the settings onto the robotic base unit and test out the balancing performance. If you want to adjust a value to improve the balancing performance, change the location of the slider and then press the run button again to load the new settings onto the robot.

After pressing the run button and uploading the values onto the robot, the run button will change to a **remote control button (G)**, which you can use as a shortcut to the remote control mode to test out driving your model with the balance settings you just chose.

Tip: Adjust the settings **in order from top to bottom**. Start with all of the settings at zero and slowly increase them until the model balances upright and shakes back and forth only slightly.

Tip: To create a balance setting file based on the current setting on the robotic base unit, open a blank balance settings file and tap the **read balance settings button (H)**.

Continue reading on the next page for explanations of the different balance settings. You can experiment with each one to see how they affect the balancing behavior.

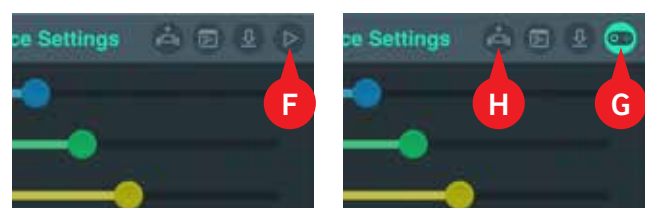
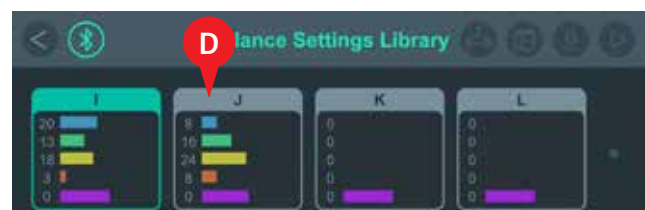
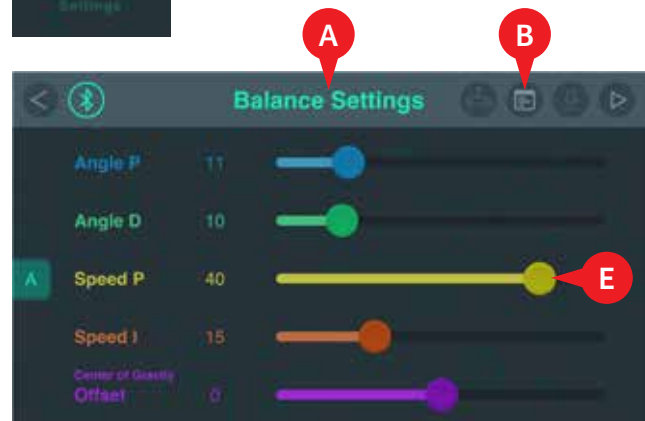

TROUBLESHOOTING THE BLUETOOTH CONNECTION

If the device connection isn't working:

- >>> Disconnect and then reestablish the Bluetooth connection.
- >>> Make sure the batteries are fully charged and the robotic base unit is on.
- >>> Exit the control app and relaunch it.



BALANCE SETTINGS CONTINUED

Set the balance settings in this order, testing them with the model after setting each one:

1. Angle P is a proportional value used to calculate how much the tilt angle of the model should be adjusted each time the calculation is run. The higher this setting, the more stable the model will remain standing — to a point. Increase this setting until the model is slightly shaking. When the value is set too high, the model will shake too much.

2. Angle D is a differential value that is also used in the tilt angle adjustment calculation. This setting helps keep the model standing stable over time. Increase the setting until the model shakes just a little bit.

3. Speed P is a proportional value used to calculate how much the wheel speed is adjusted each time the calculation is run. The higher this setting, the shorter the distance the model is given to stop. Increase the value of this setting until the model is stable. If the value gets too high, the model will sway backward and forward a lot.

4. Speed I is an integral value that is used to make smaller adjustments to the wheel speed. Each time the calculation is run, the Speed I will cause the Speed P to increase a small amount. This setting helps to further stabilize the model when moving.

5. Center of Gravity Offset: This setting accounts for the different centers of mass (or centers of gravity) for the different models. Adjust this setting to change the angle at which the model stands.

Together with the input from the sensors, these balance settings are processed by the microcontroller, which results in output sent to the motors and the wheels that is constantly updating to keep the robot balanced.

Side view diagram of balancing robot:

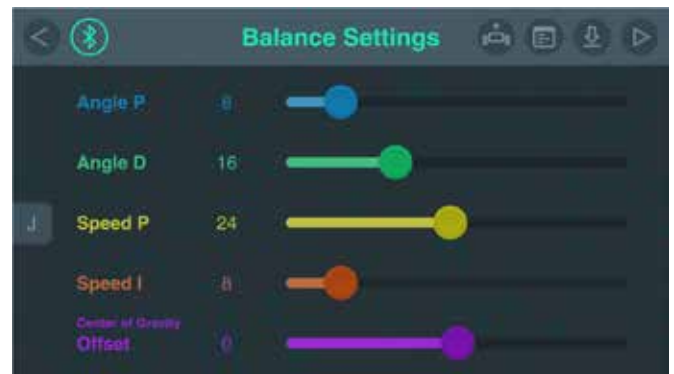
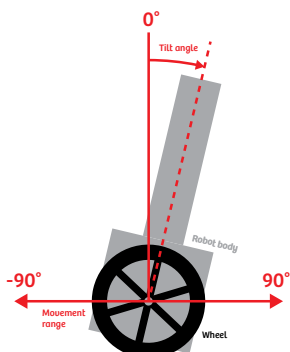

Scan this QR code to view a video tutorial showing how to use the balance settings.

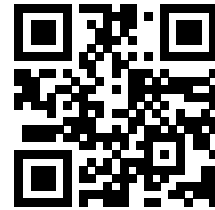

TROUBLESHOOTING THE BALANCE SETTINGS

Here are some tips if you can't get your model to balance:

- »» Different floor or table surfaces will affect the balancing performance. Relatively smooth (but not slippery) and flat surfaces are best. Test out different surfaces.
- »» If your robot can't balance itself after you hold it upright for five seconds, please turn the balancing I/O switch off and on again in the remote control mode.
- »» Keep a small gap between the edges of the wheels and the robotic base unit so that the wheels turn smoothly.
- »» Always start a model like this: First, position the model with its wheels on the floor and then turn on the switch. Hold the robot upright until you feel the motors working. This helps the model balance.
- »» When the robot detects unusual movement, such as a sudden change in the motor's turning direction, a feature designed to protect the motor from damage will be initiated. When this occurs, you must turn off the robot for three seconds and then turn it on again.
- »» Sudden or frequent changes in the motor's turning direction or powerful external forces pushing on the models will cause them to fall down.
- »» The balance settings will need to be adjusted for different floor or tabletop materials, models, and battery power levels.

PROGRAMMING MODE

BALANCING ROBOTS PROGRAMMING MODE

To write and run programs for your balancing robots, use the **programming mode (A)**. To program all of the robot models built in these instructions, use the balancing robots programming mode.

1. Tap the **balancing robots programming mode button (B)**. The **balancing robots programming screen appears (C)**.

2. To load a preset program for a specific model, tap the **folder icon (D)** and select the **name of the model (E)**. A **window** will pop up asking you if you want to open the program or cancel and return back to the program library **(F)**. Tap open to open the program.

3. Each program specifies a balance setting to be used with that program. The **balance setting specified** by a program is shown by the **tab with the letter in it** on the left side of the screen **(G)**. You can change the balance setting by pushing this tab and entering the balance settings library.

4. A program consists of a series of **command steps (H)**. Each has three main parts: **motion (I)**, **light (J)**, and **sound (K)**. Each motion command step has three parts: the **motor power (L)**, **turning angle (M)**, and **duration (N)**.

The **motor power** controls how much power is applied to the motors and relates to the speed at which the motors and the wheels turn. The power level can be set from -40 to +40 in increments of 1, with negative values causing the model to drive in reverse and positive values causing the model to drive forward.

The **turning angle** controls the direction in which the model turns and the degree to which it turns. It can be set to 0 to 90 left or 0 to 90 right in increments of 15. A value of 0 means the model moves straight forward. A value of 60 results in a sharper turn than a value of 30. A value of 90 is the sharpest turn to the side, where one wheel turns one direction and the other wheel turns the other direction and the model pivots in place.

The number at the bottom of the blue motion command step indicates the **duration of time** for which this command step is active. It can be set to 1 to 5 seconds, in 0.25 second increments.

A **light effect** and a **sound effect** can be assigned to each command step as well.

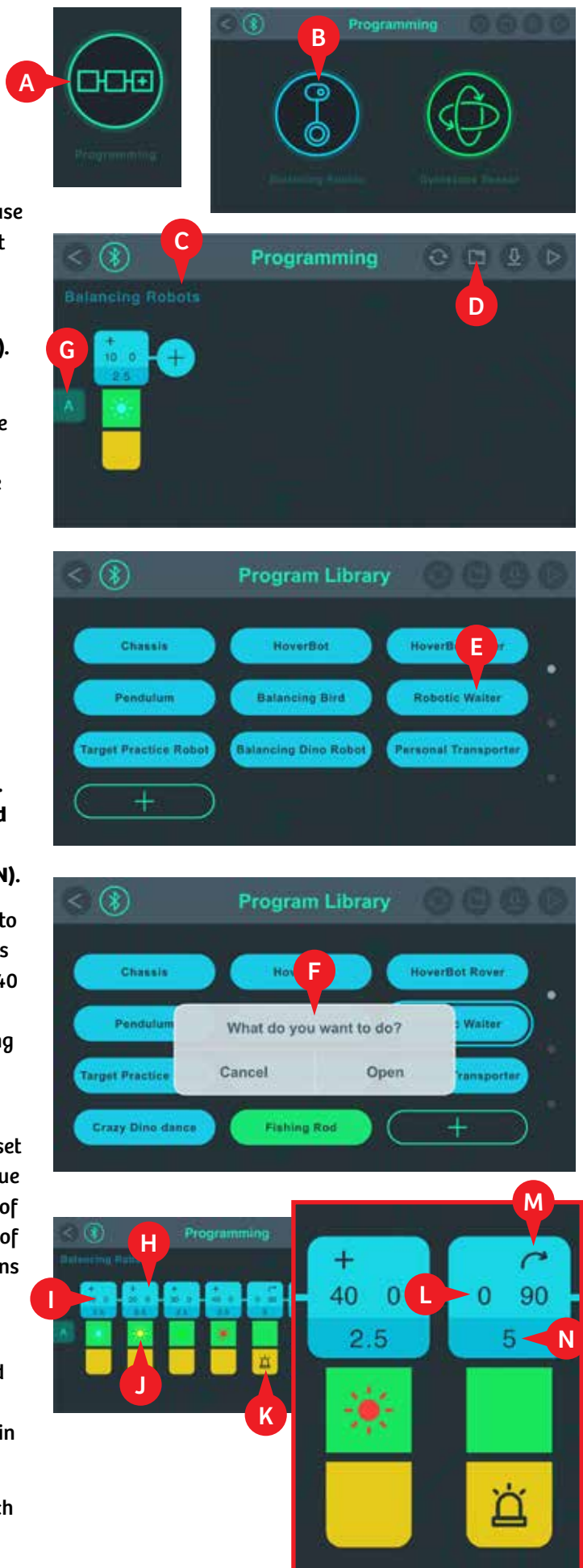



PROGRAMMING MODE

Writing a Program

To create a command step, press the **circular plus sign button (A)**. The command step settings window will appear.

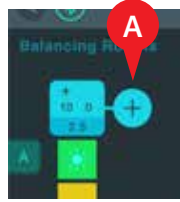

There are three tabs on the command step settings window: **motion (B)**, **lights (C)**, and **sounds (D)**.

On the motion tab, use the sliders to set the values for the **motor power (E)** and **duration (F)**. Use the buttons to set the **turning angle (G)**.

On the lights tab, select the **color of the light (H)** you want to light up inside the robotic base unit during the duration of this command step.

On the sounds tab, select the icon symbolizing the **sound effect (I)** you want to play during the duration of this command step.

Tap the **check mark icon (J)** to save your command step into the program.

Tap the **trash can icon (K)** to delete a command step.

To save a program, press the **save button (down arrow icon, L)**.

To reset a program to its original state, press the **reset button (rotating arrows icon, M)**. The reset button will reset a preset program to its original command steps. For a user-defined program, the reset button will clear all the command steps, resetting it back to its original blank state.

Running a Program

When you are ready to run a program, press the **run button (triangle icon, N)**.

As the program runs, the **highlighted command step (O)** shows the part of the program that is actively being performed by the robot.

If you want to stop the program at any time, tap the **stop button (P)**.

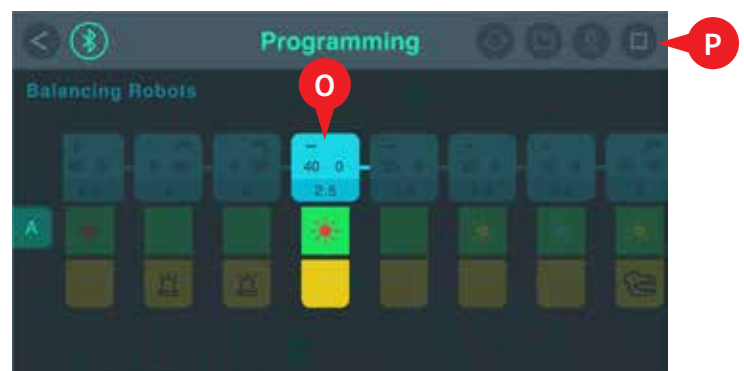

PROGRAMMING MODE

GYROSCOPE SENSOR PROGRAMMING MODE

You can also write programs that will perform different commands depending on the angle of the **gyroscope sensor** inside the robotic base unit.

This programming mode is not used with the models in this kit. It is an extra experimental feature that helps demonstrate the functionality of the gyroscope sensor.

To enter the **gyroscope sensor programming mode**, tap its icon (A) on the main programming page.

The **gyroscope sensor programming mode screen** appears (B).

You can write a program segment to run under each of three states of the gyroscope sensor: **Tilted to the left (C)**, **upright (D)**, and **tilted to the right (E)**. You can control the **motion (F)**, **lights (G)**, and **sounds (H)** with the program command steps.

You can press the **loop button (I)** to make the program segment loop as long as the sensor is reading that tilt angle.

Gyroscope sensor programs are also saved in the program library, next to the balancing robots programs. The **gyroscope sensor programs are green (J)**, and the **balancing robots programs are blue (K)**.

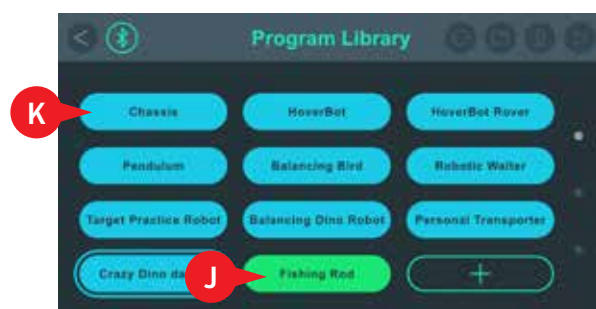
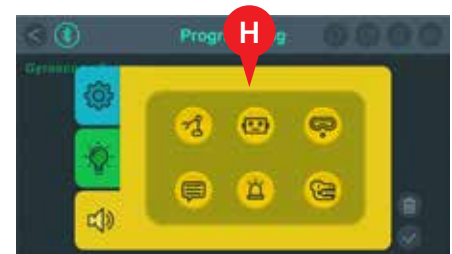
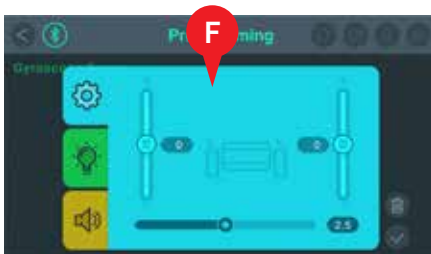
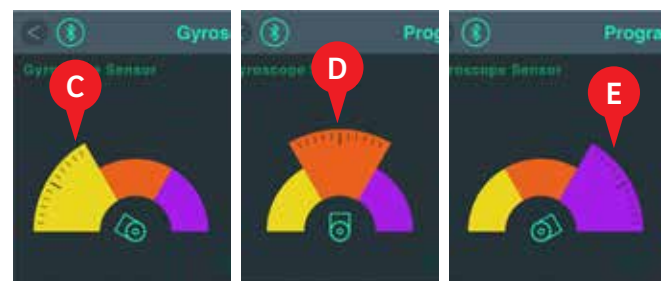



HOVERBOT AND ROVER

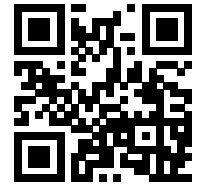

DIGITAL ASSEMBLY INSTRUCTIONS

Scan this QR code to open the product web page. Then, tap the link to access the digital assembly instructions app.

First, follow these assembly instructions to build the model. Then, you can use the model in remote control mode, or you can follow the instructions on the programming page immediately after these assembly instructions to run a program for this model.

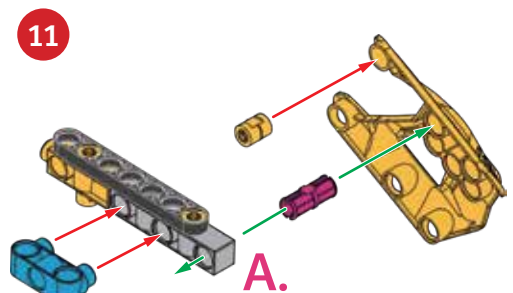
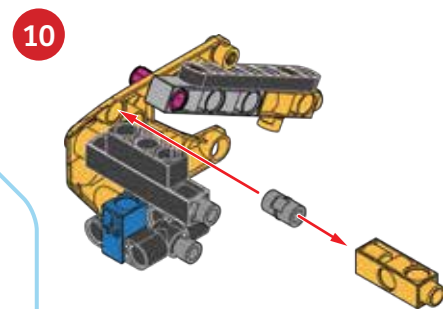
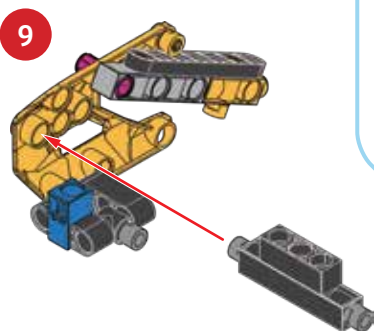
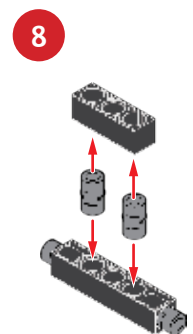
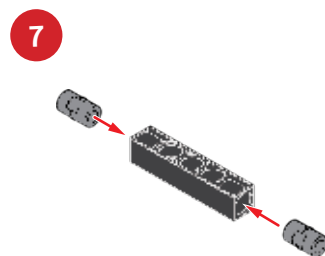
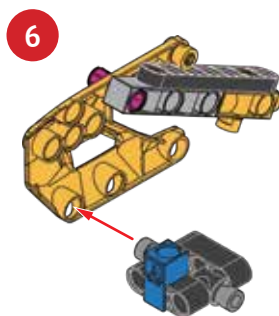
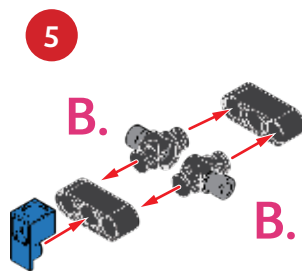
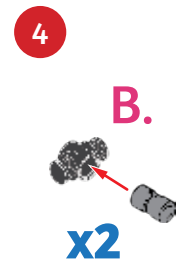
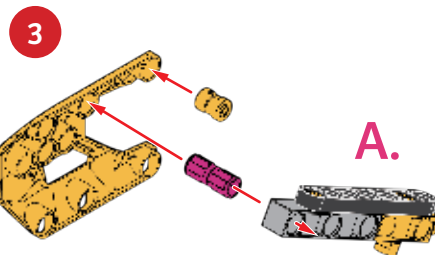
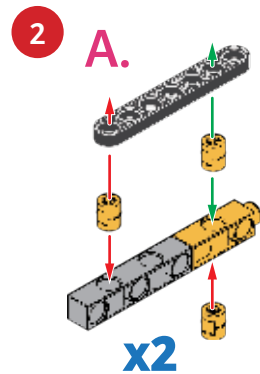
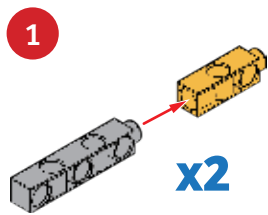
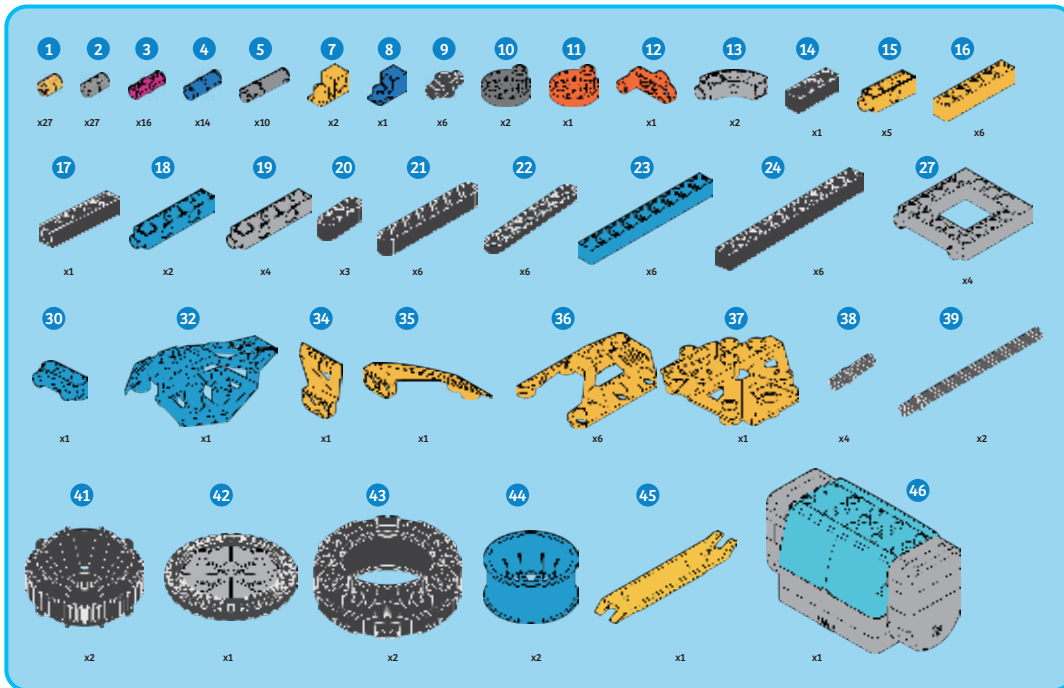

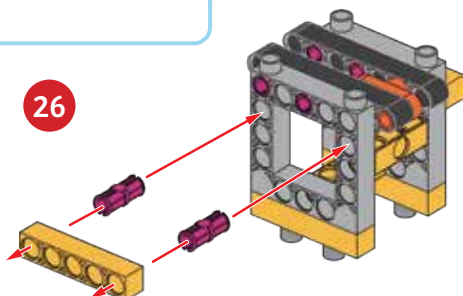
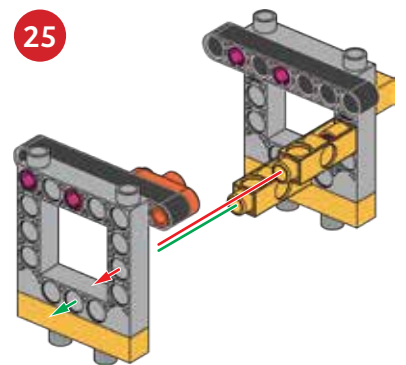
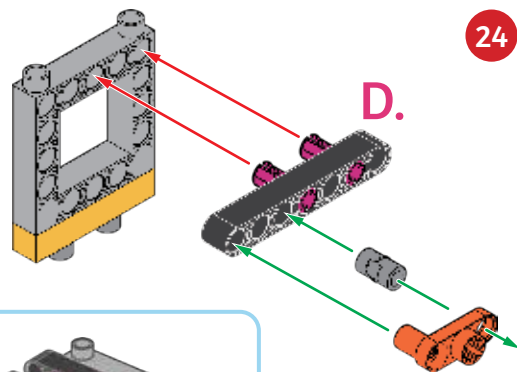
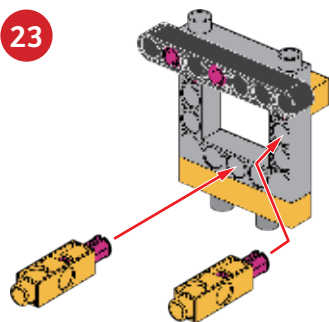
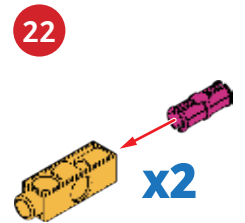
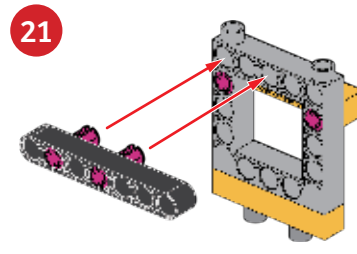
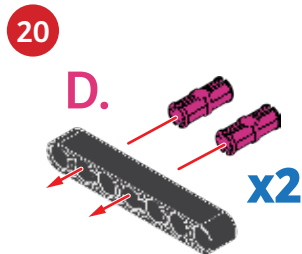
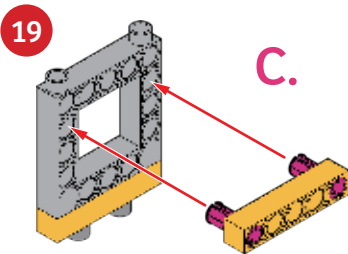
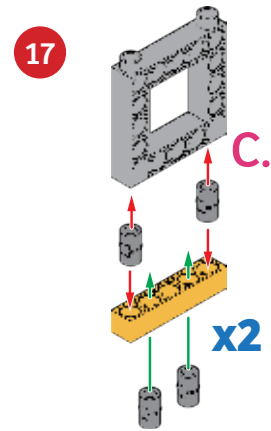
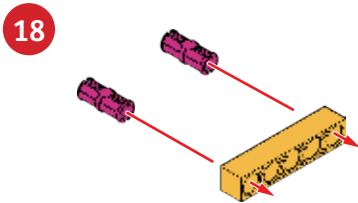
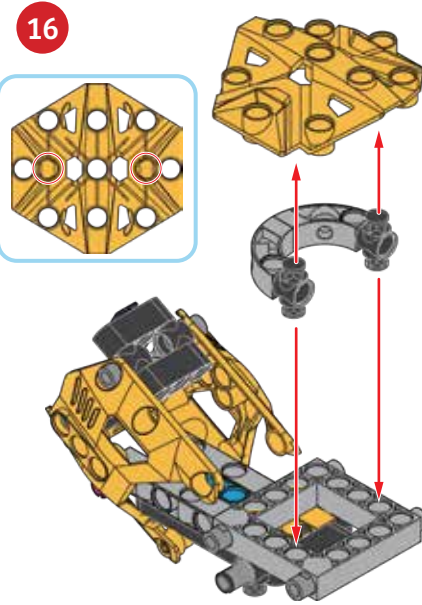
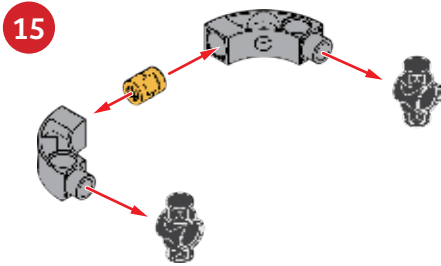
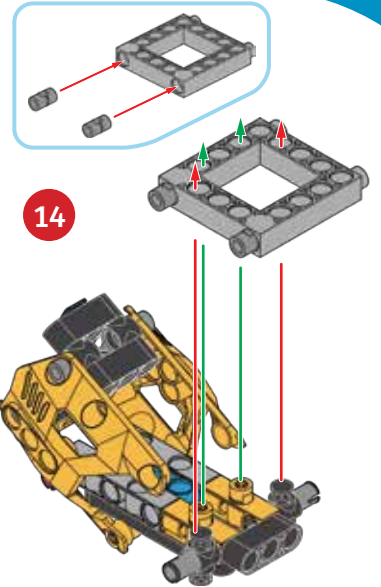
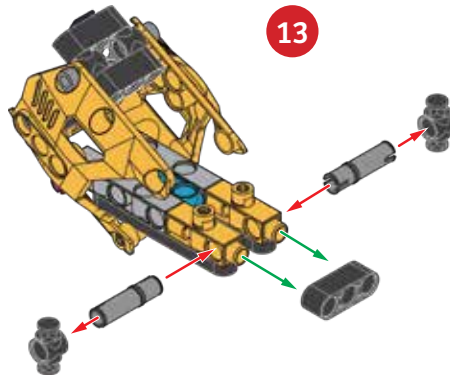
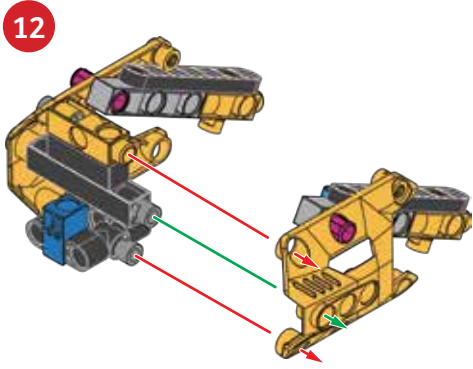



HOVERBOT AND ROVER

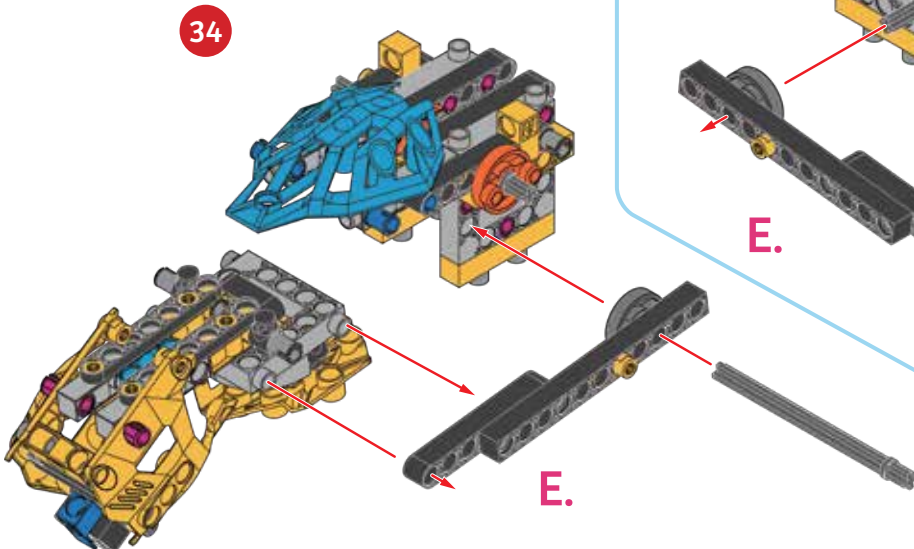
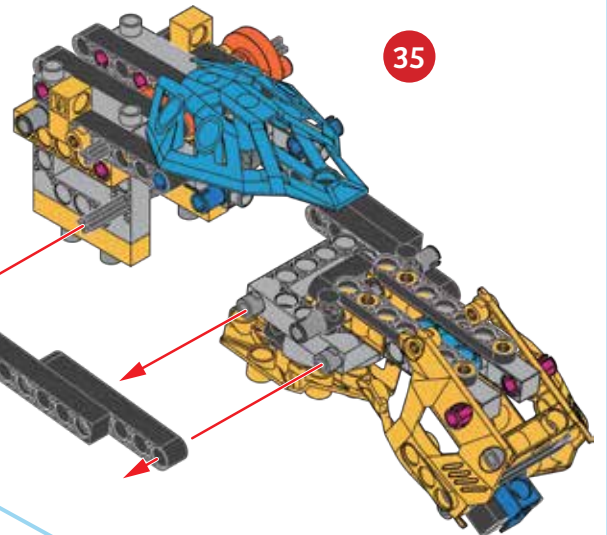
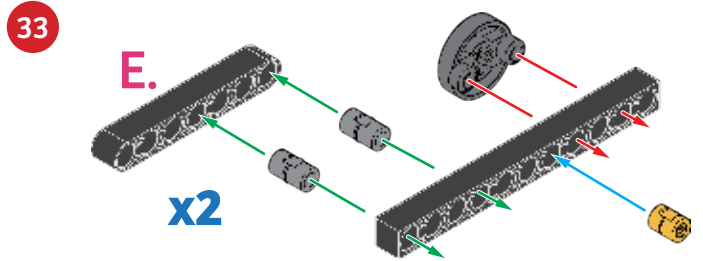
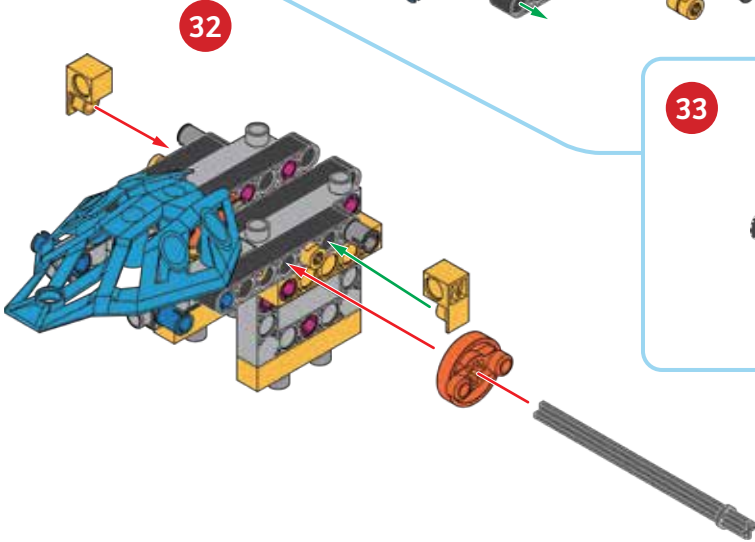
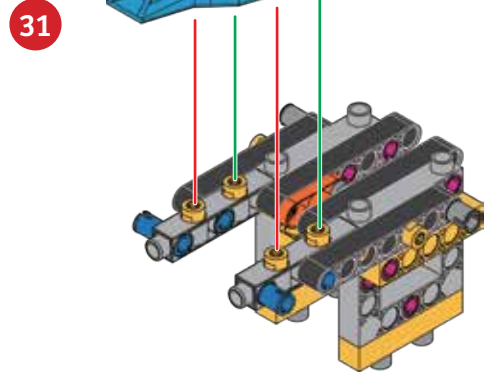
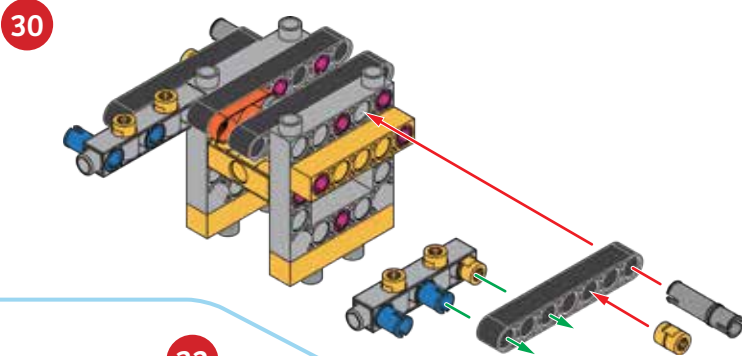
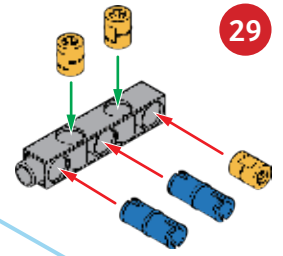
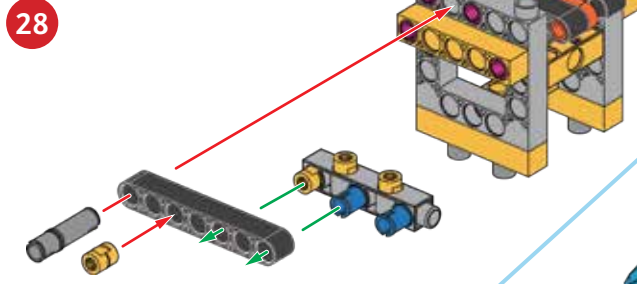
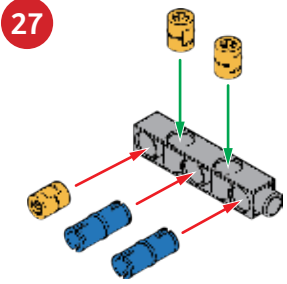

36

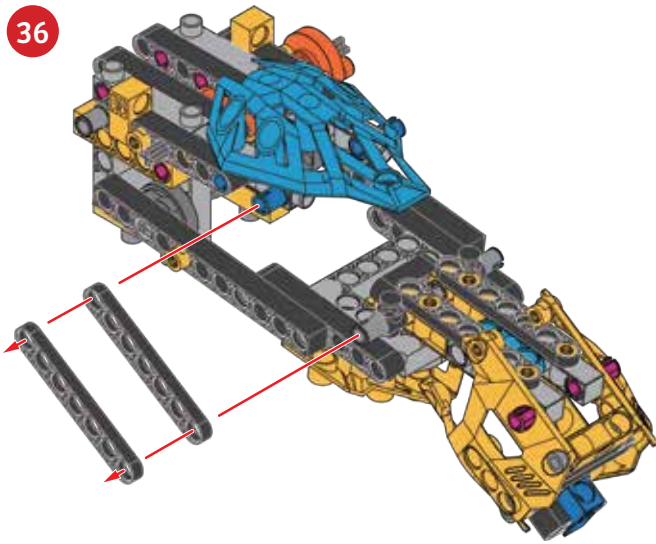

37

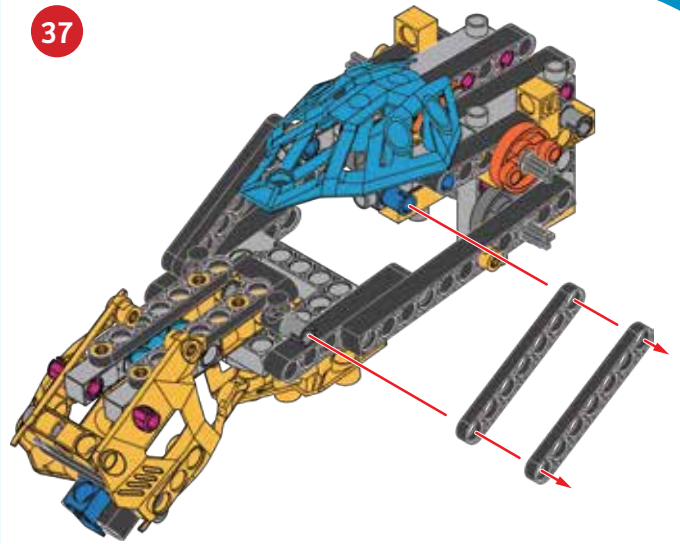

38

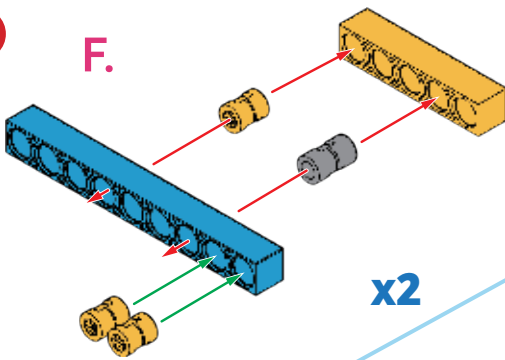

39

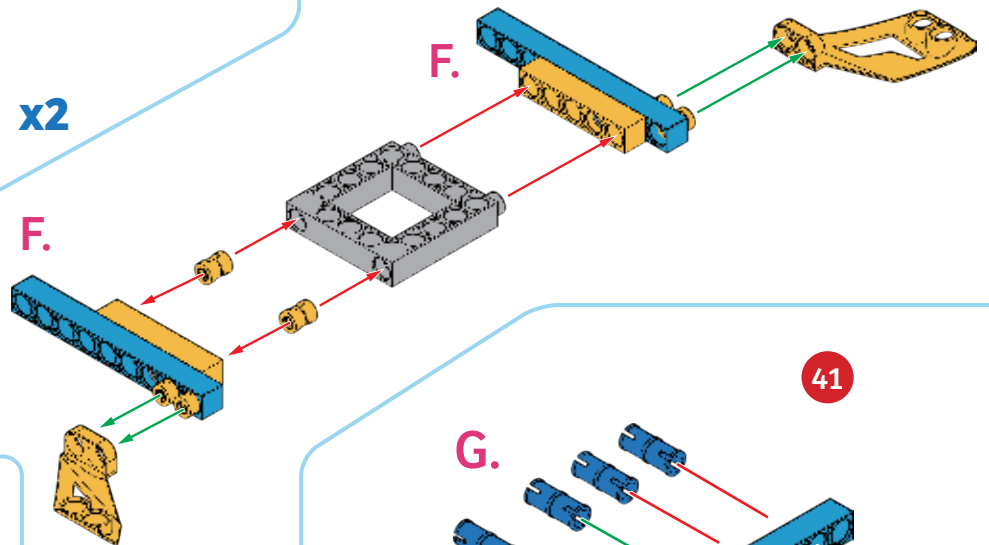

40

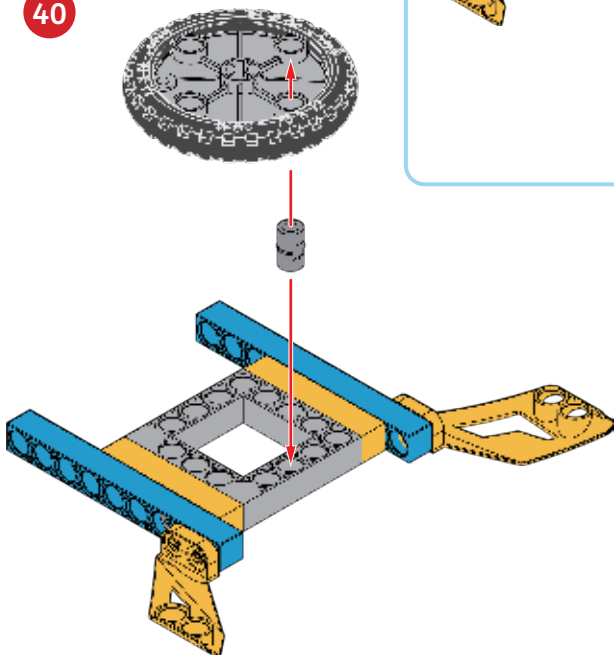

41

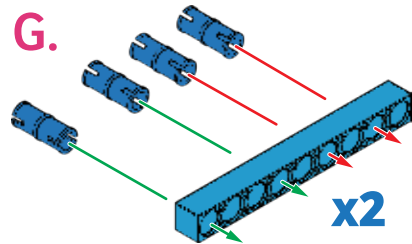

42

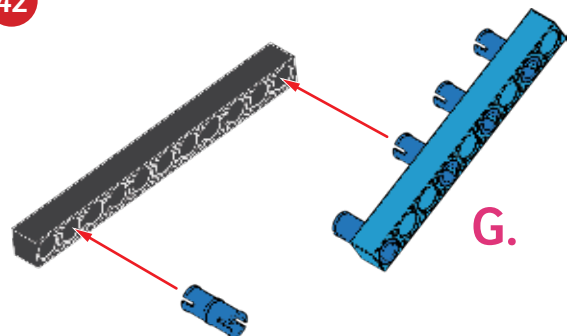



HOVERBOT AND ROVER

43

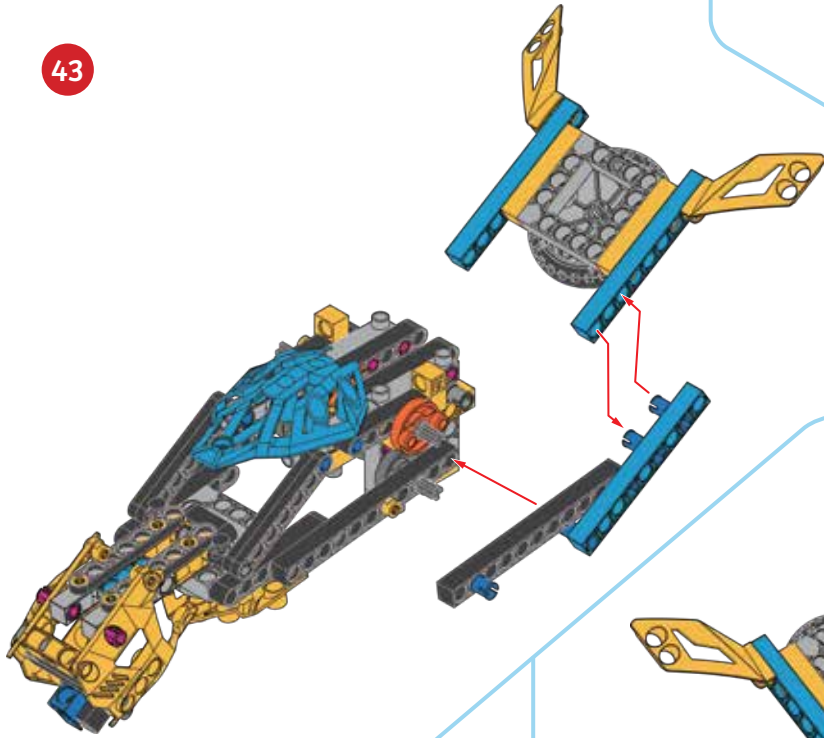

G.

44

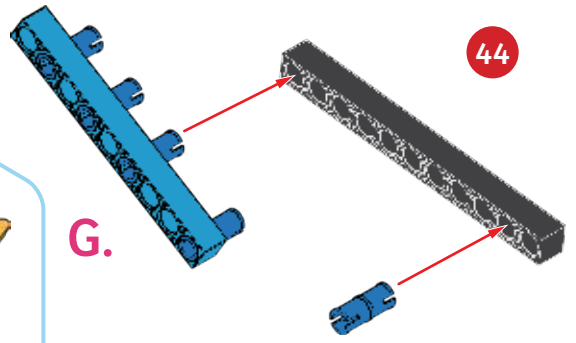

45

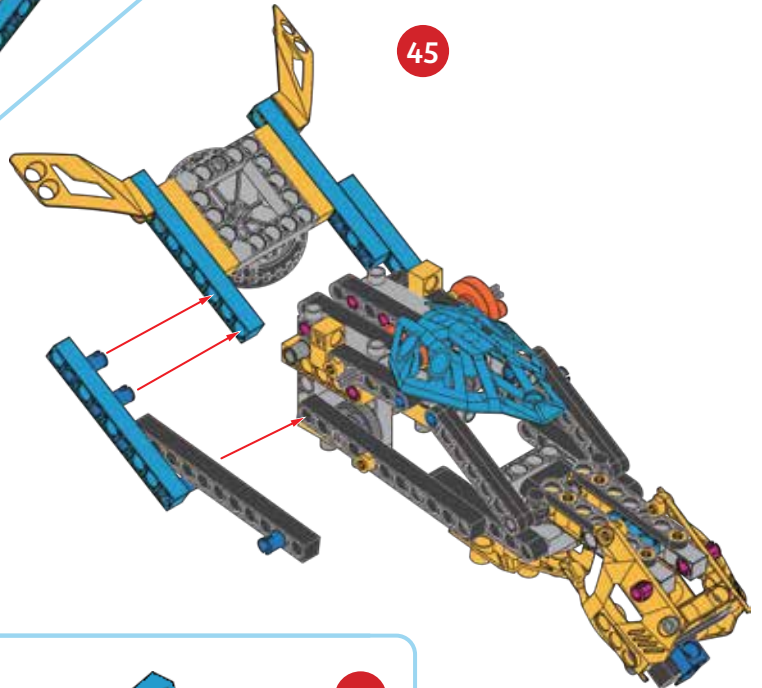

46

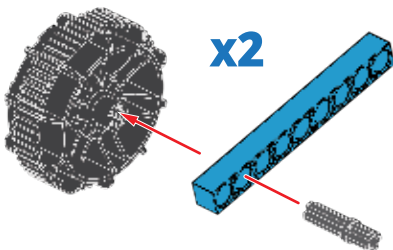

x2

47

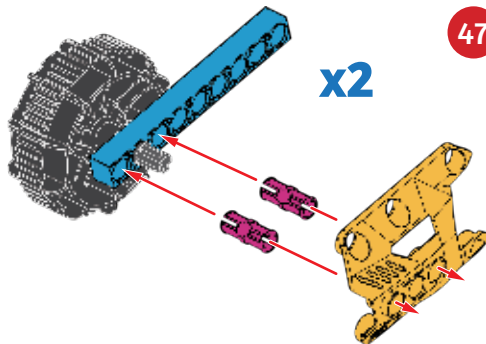

x2

48

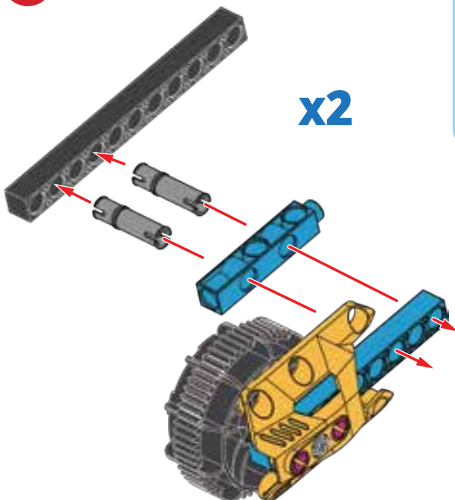

x2

49

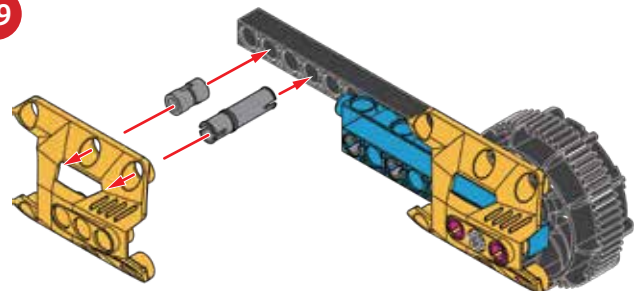

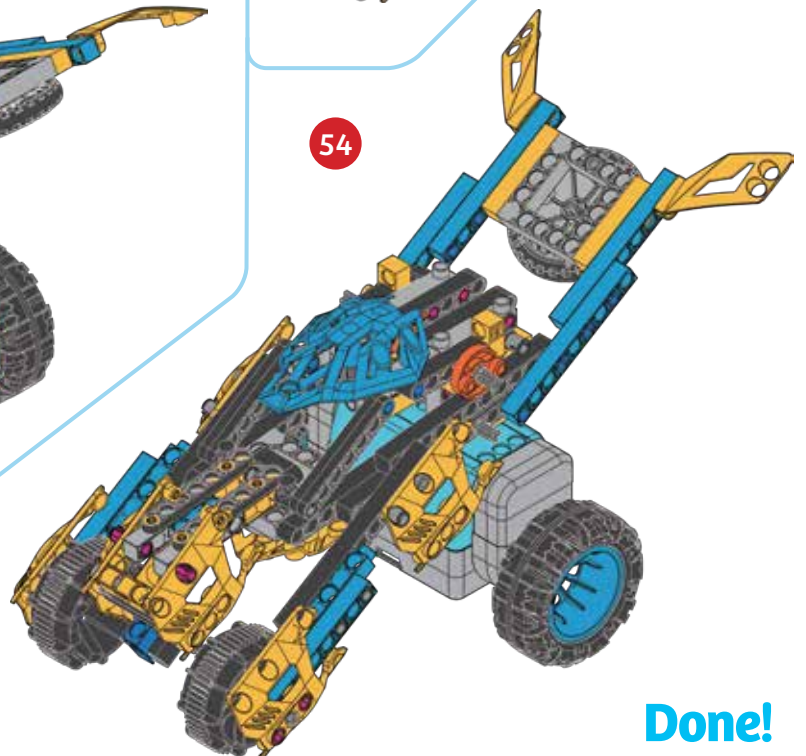
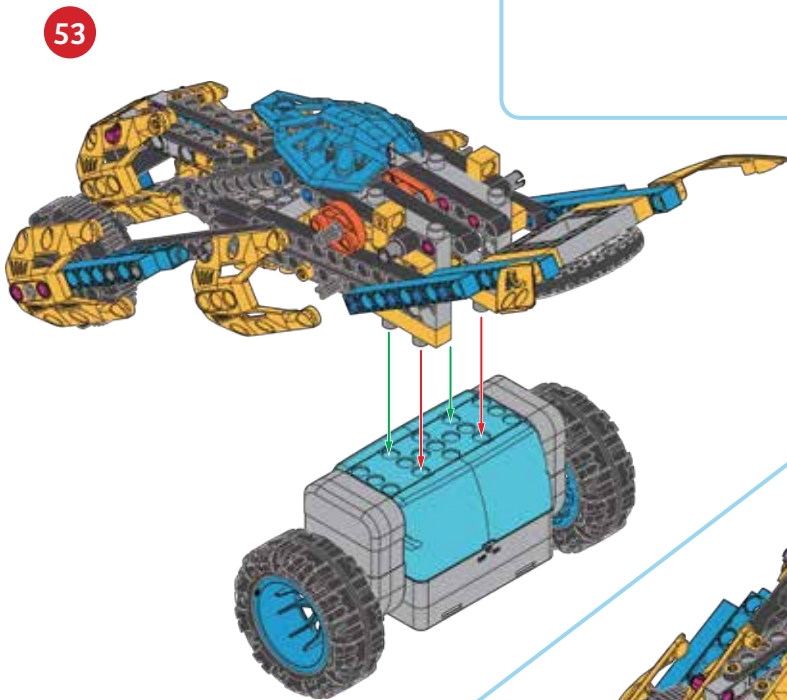
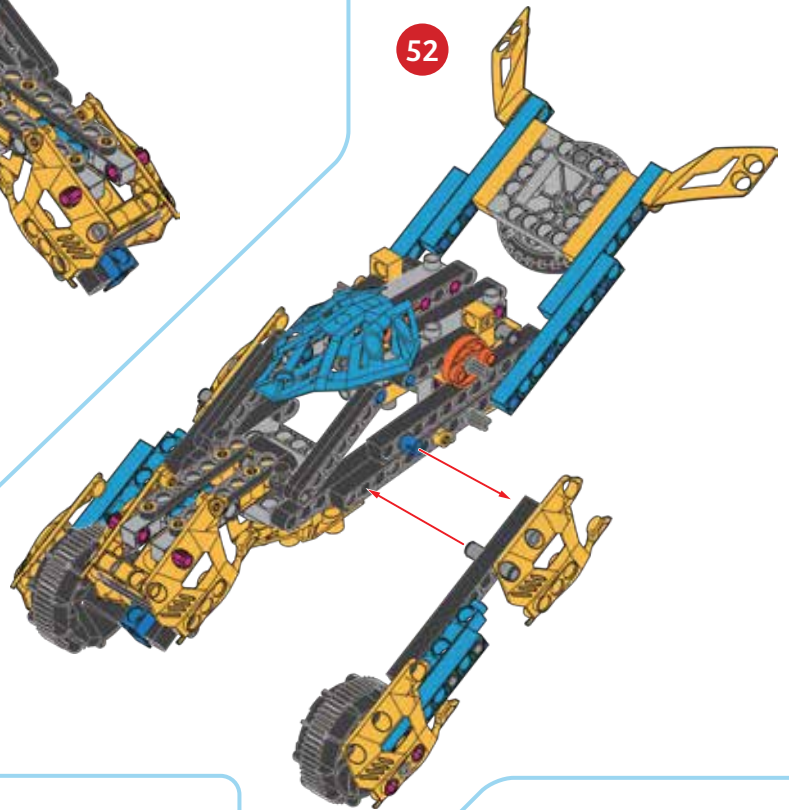
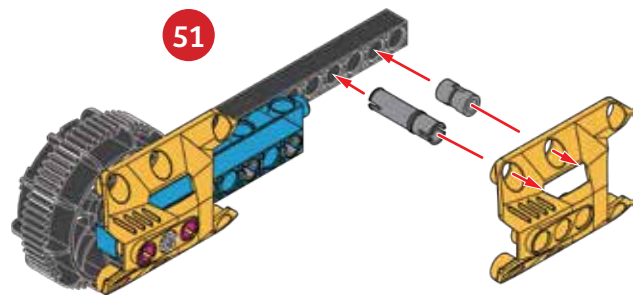
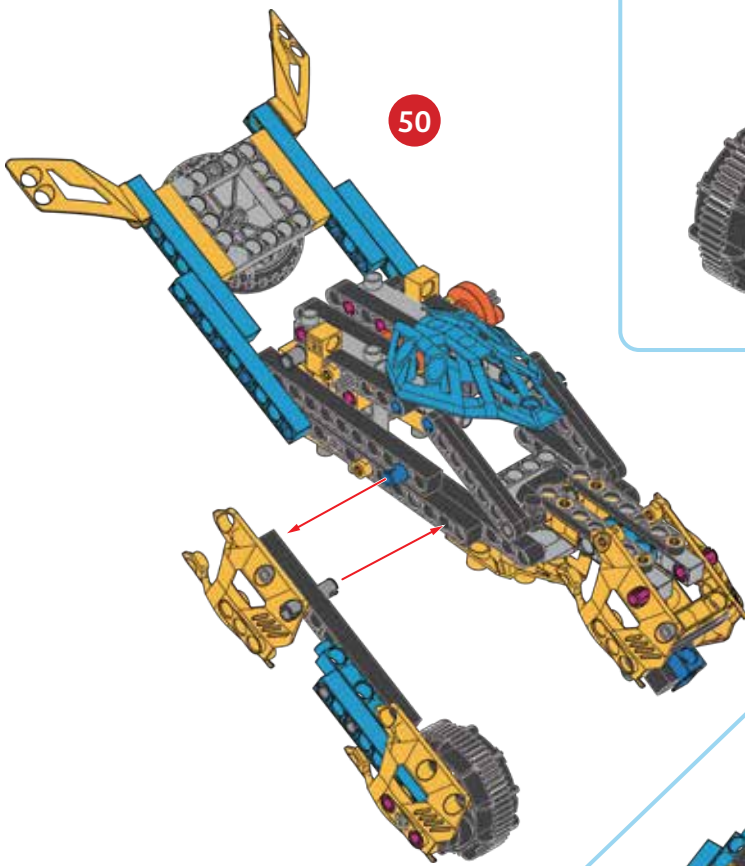

Done!



SAMPLE PROGRAM FOR THE HOVERBOT IN ROVER MODE

1. After you have built the model using the assembly steps on the previous pages, keep the model in rover mode to run the first sample program. Put the model on the floor in an open area and turn it on. Establish the Bluetooth connection with the app.
2. Open the **HoverBot Rover** program. Note that the balance setting is set to **C**.
3. Press the run button. Observe the robot's actions as it runs the program. Below, write down what the robot does for each command step of the program.

Balance Setting:

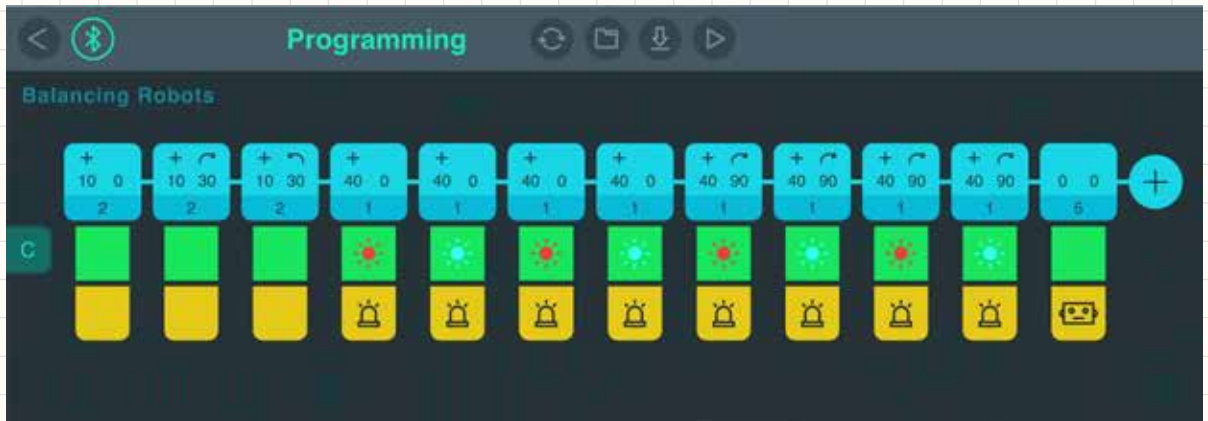

WHAT'S HAPPENING? Record your observations here.



CHECK IT OUT



Self-balancing scooters

You have probably seen and maybe even ridden on a **self-balancing scooter** (also called a **hoverboard** or a **self-balancing board**). These personal transportation devices have two motorized wheels with a platform for a rider to stand on between them. The platform has a pivoting joint in the middle. The rider steers the scooter by twisting the two sides of the platform. The rider controls the speed by leaning forward and backward. These vehicles use a balancing technology similar to the one used in the robots in this kit.





TRANSFORM ROVER INTO HOVERBOT

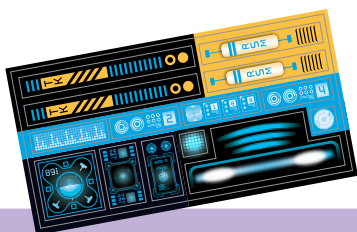
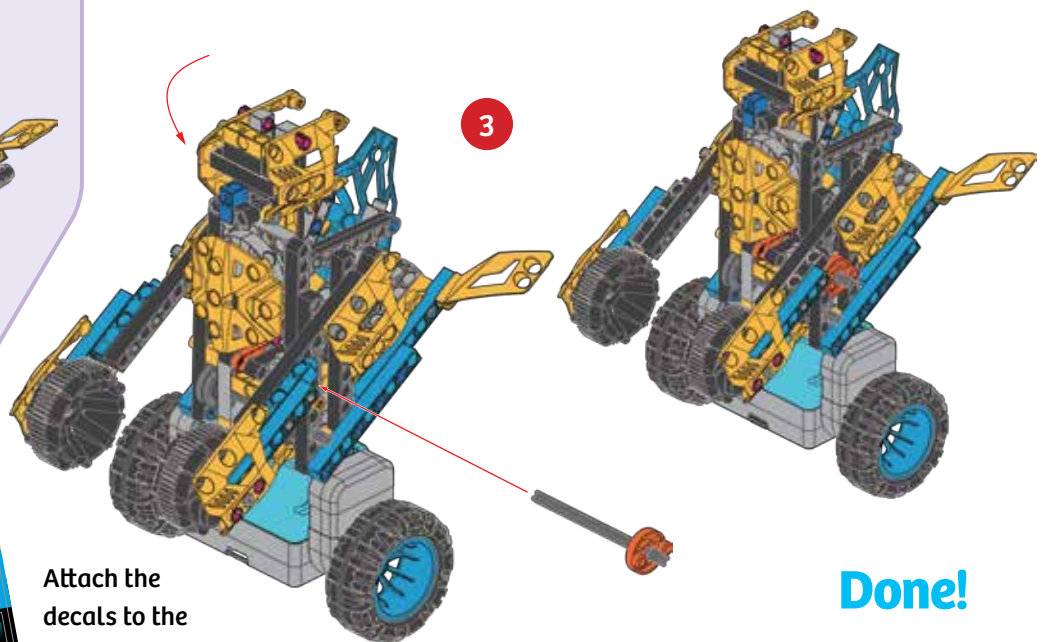
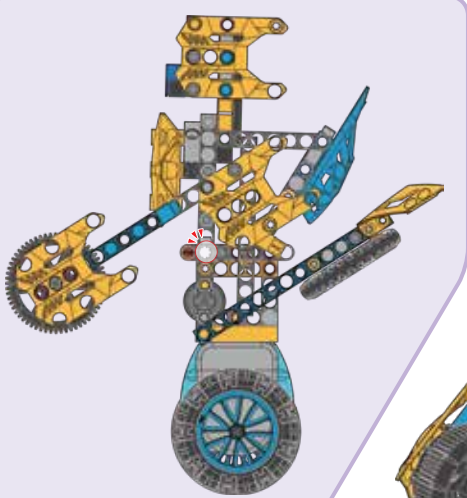
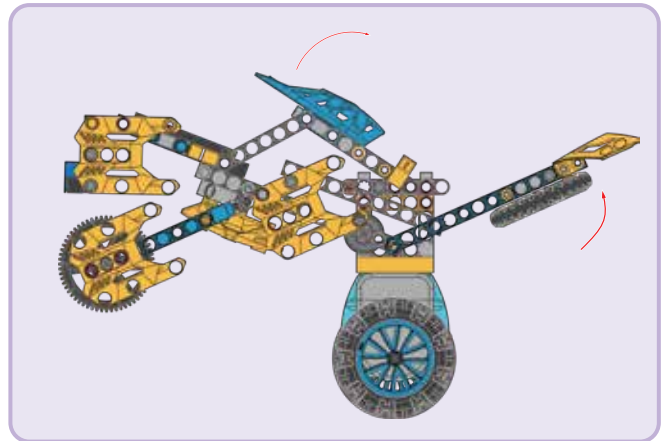
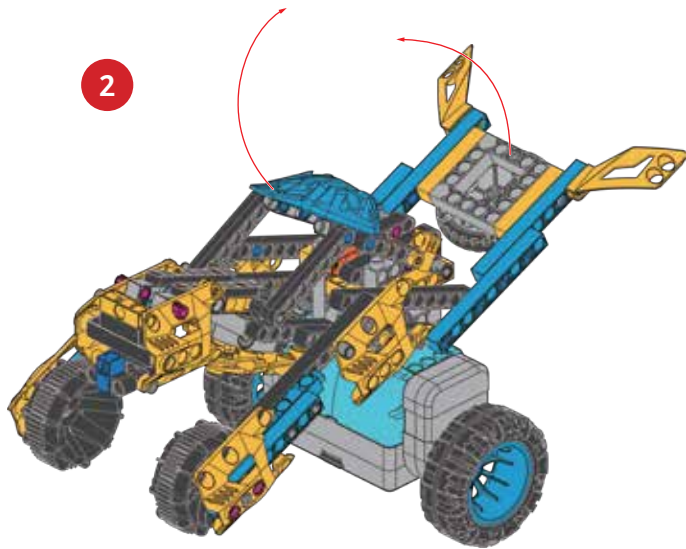
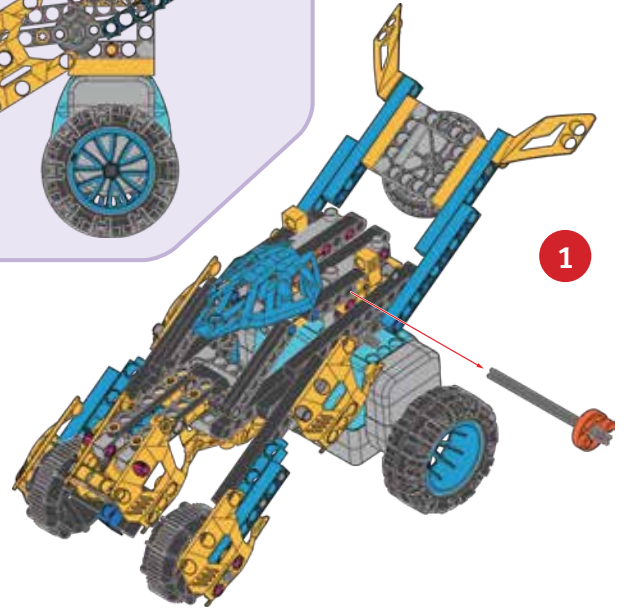
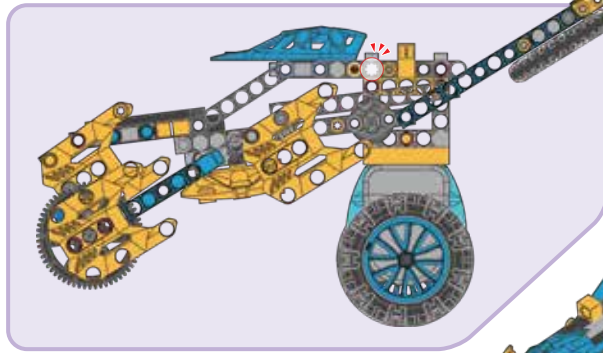
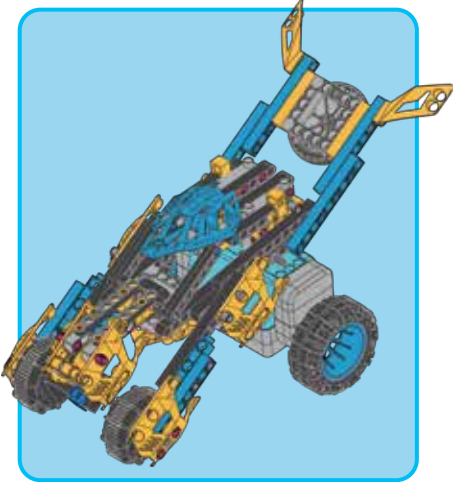

Attach the decals to the model.

Done!

PROGRAMMING



SAMPLE PROGRAM FOR THE HOVERBOT

1. Convert the Rover into HoverBot mode using the instructions on the previous page. Put the model on the floor in an open area. Hold it upright and turn it on.

Because the robot remembers the previous balance setting, the robot may not be balancing perfectly. That's okay — when you run the program, the correct balance setting will be applied to the robot.

2. Establish the Bluetooth connection with the app. Open the **HoverBot** program. Note that the balance setting is set to **B**.

3. Press the run button. Hold the robot until it is standing upright and balancing on its own. Observe the robot's actions as it runs the program. Below, write down what the robot does for each command step of the program.

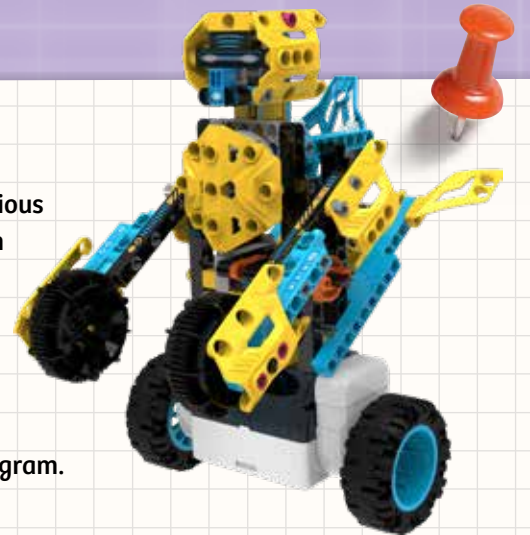

Balance Setting:

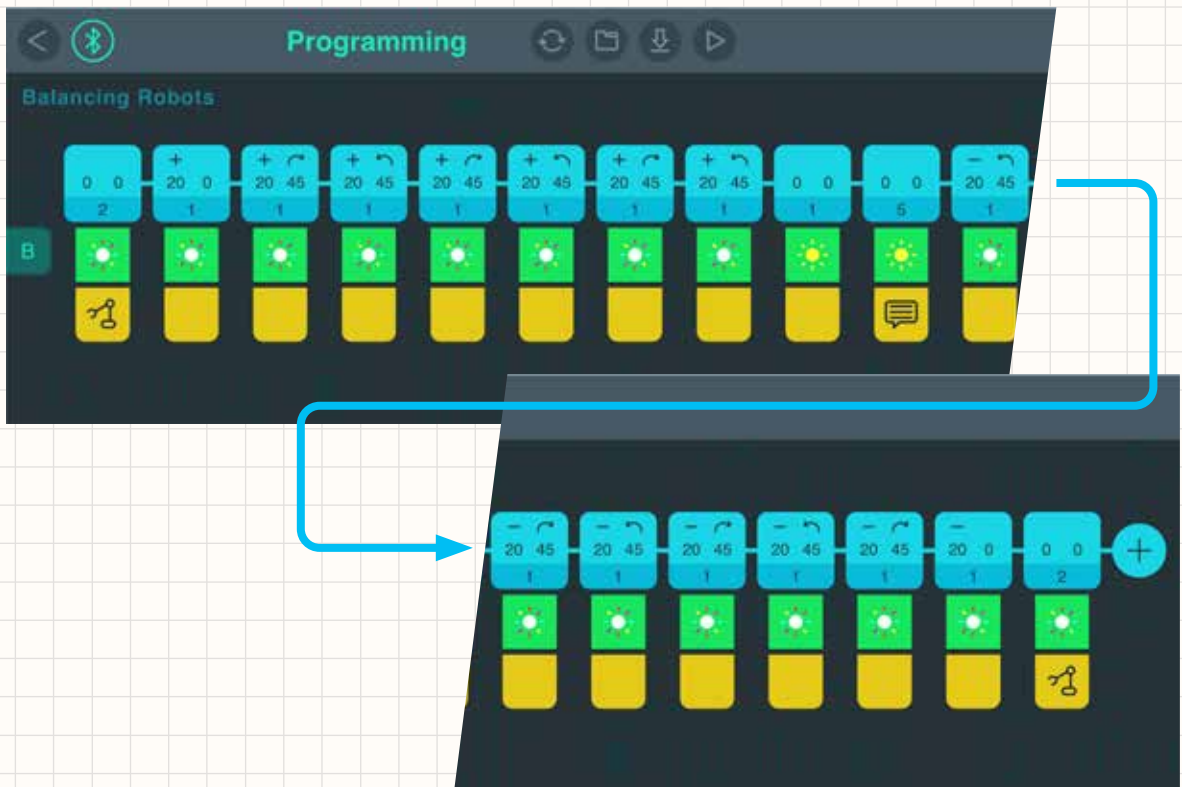

WHAT'S HAPPENING? Record your observations here.



CHECK IT OUT

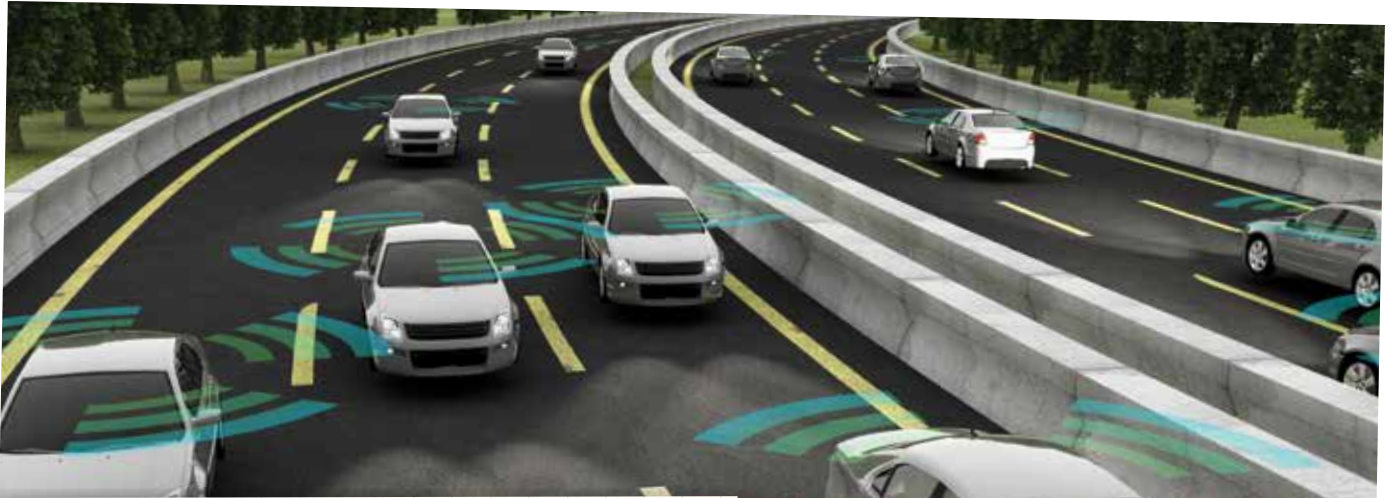

Robotic Cars

The HoverBot Rover model is a self-driving robotic automobile. Can you imagine drivers watching a movie or reading a book while they drive around town? Or texting their friends while driving — completely safely? Well, you can't do that in conventional cars today, but self-driving cars appear to be the way of the future.

Automotive engineers expect that by 2020 it will be completely normal for some cars to drive mostly on their own, and by 2030 most of the cars on the roads will be **self-driving, or autonomous, vehicles**. Many car companies and tech companies are actively developing autonomous vehicles. Below is a list of the technologies used in self-driving cars:



- A **3D camera** scans the roads for the driving lanes and traffic ahead.
- A **laser scanner, called LIDAR**, detects every street sign and traffic signal along with other cars and pedestrians.
- **Radar systems** in the front and the back of the car keep the car from running into other objects.
- A precise **GPS navigation system** determines the car's position down to inches.
- A **computer** will take all the data from the sensors on the car, process it, and make virtually instantaneous decisions about the car's speed and direction.

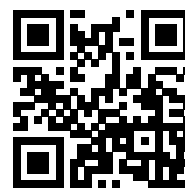

DIGITAL ASSEMBLY INSTRUCTIONS

Scan this QR code to open the product web page. Then, tap the link to access the digital assembly instructions app.

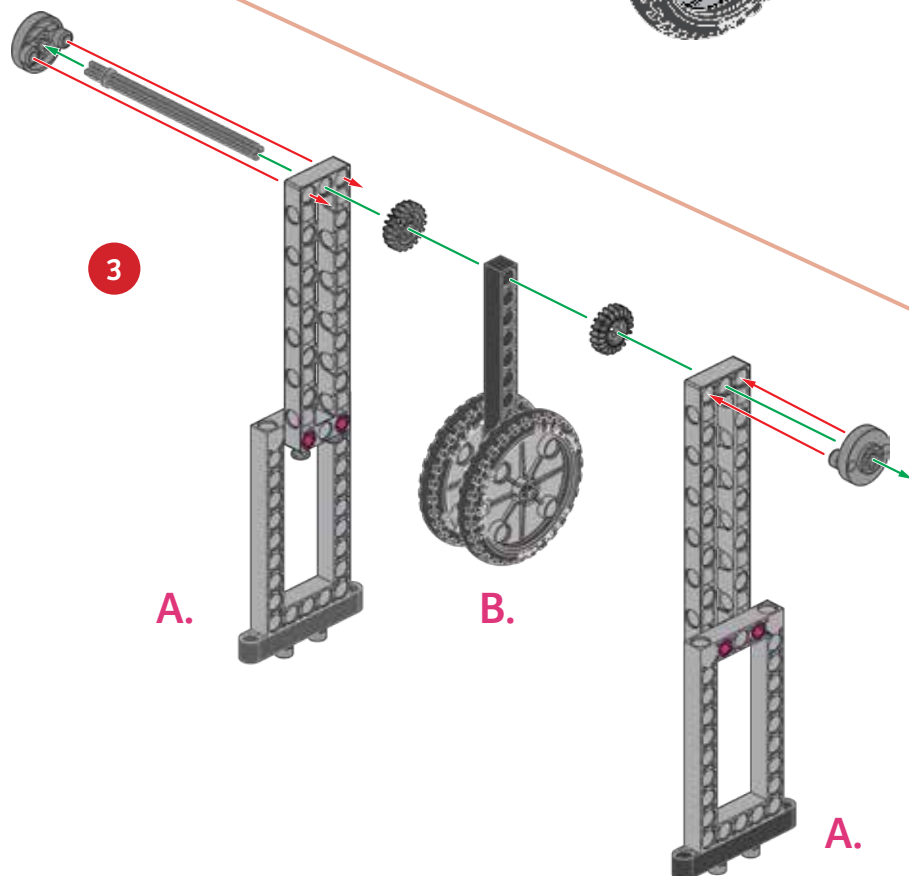
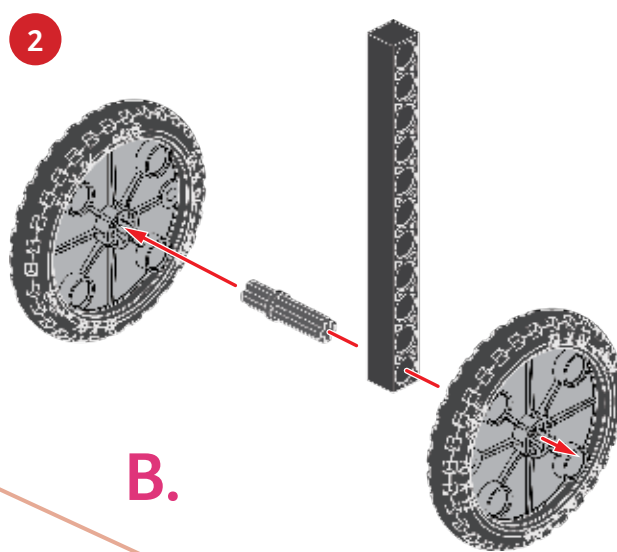
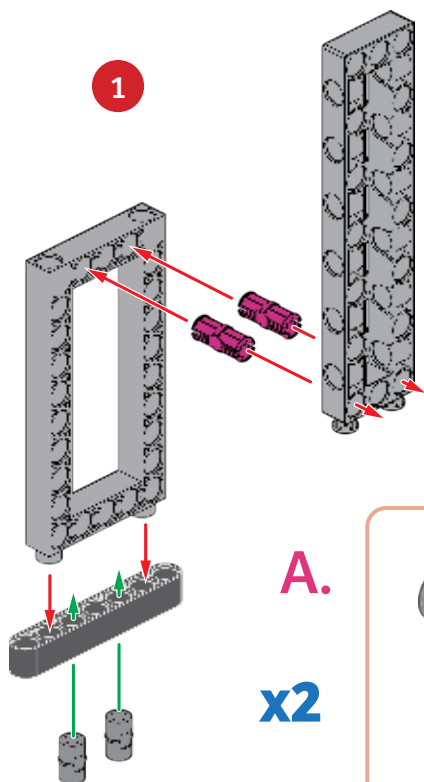
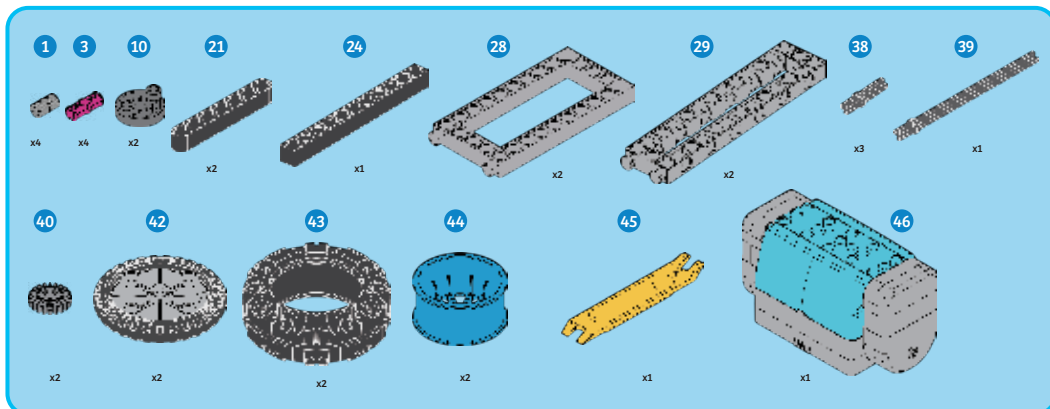



4

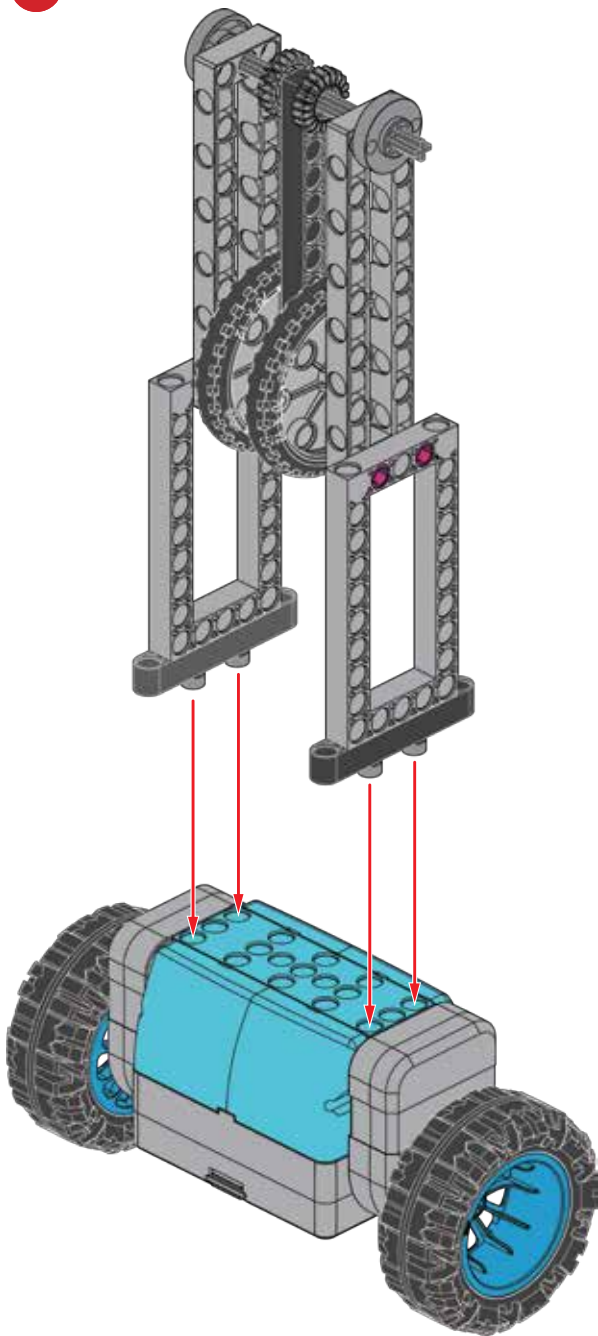

5

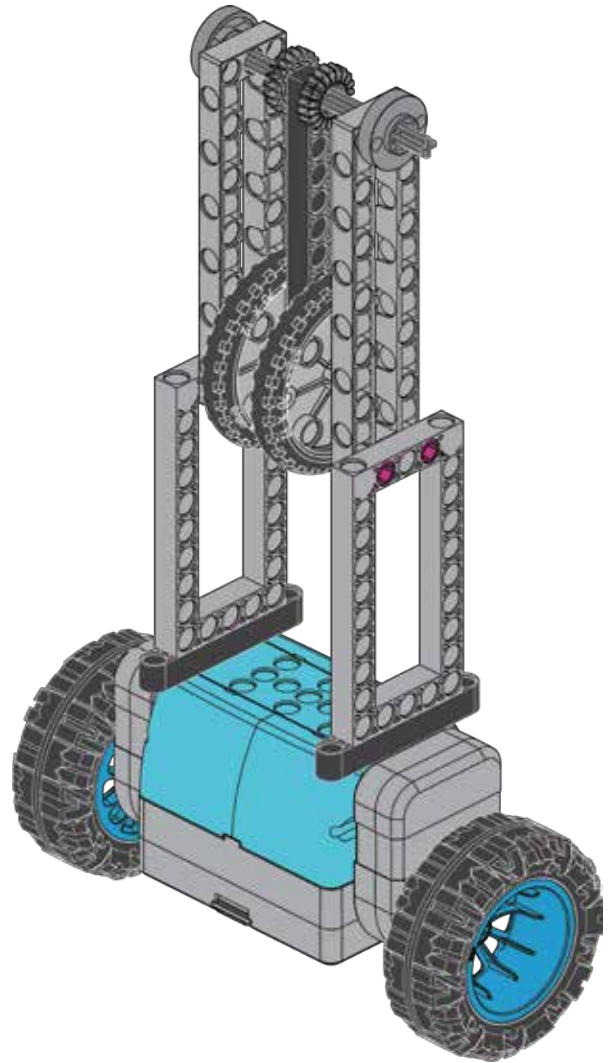

Done!

PROGRAMMING



SAMPLE PROGRAM FOR THE PENDULUM

1. Assemble the model using the instructions on the previous pages. Put the model on the floor in an open area. Hold it upright and turn it on.
2. Establish the Bluetooth connection with the app. Open the **Pendulum** program. Note that the balance setting is set to **D**.
3. Press the run button. Hold the model until it is standing upright and balancing on its own. Observe the pendulum's behavior as the robot runs the program. Below, write down what the robot does for each command step of the program.

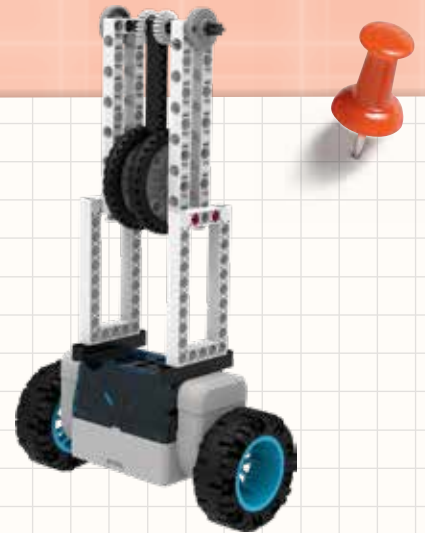

Balance Setting:

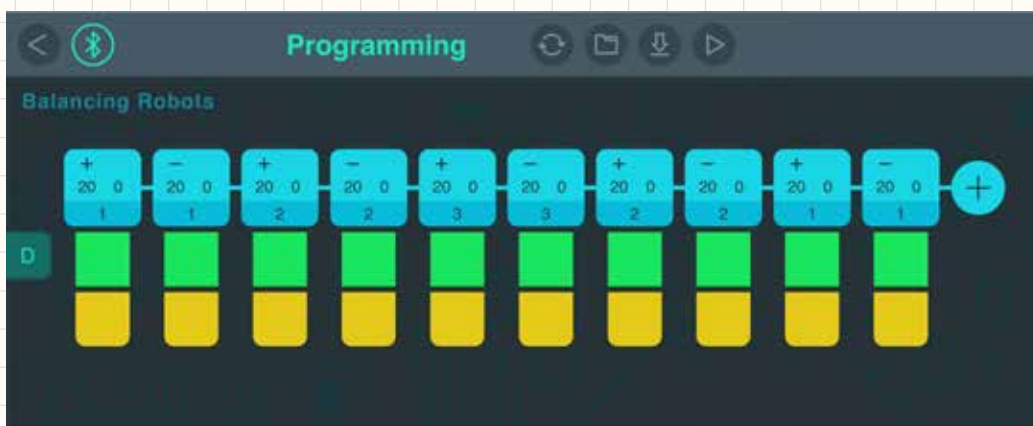

WHAT'S HAPPENING? *Record your observations here.*



CHECK IT OUT

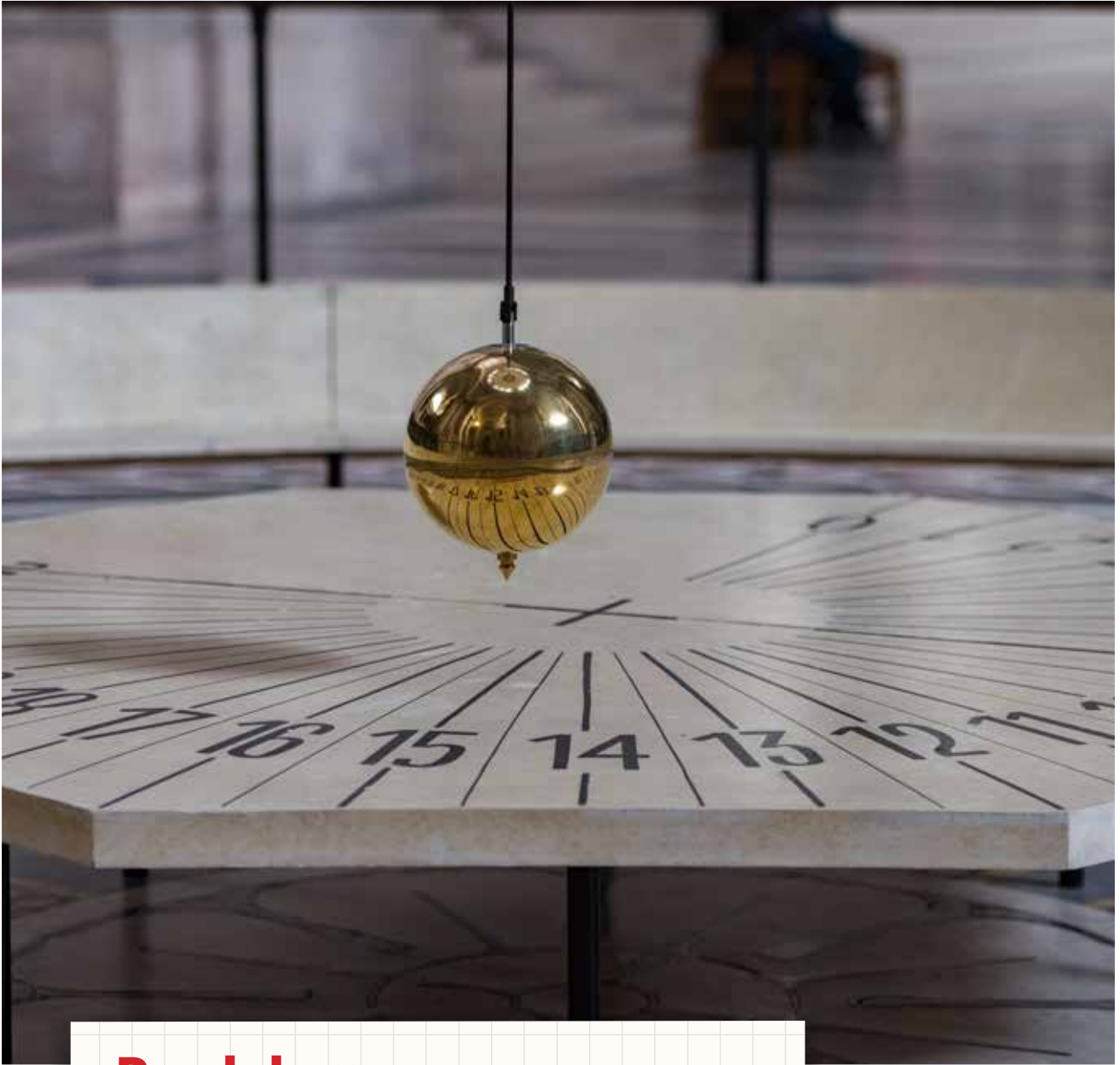

Pendulum

A **pendulum** is a weight suspended from a pivot that can swing freely. When the pendulum swings to the side from its central resting place — called the **equilibrium position** — gravity pulls it back toward the equilibrium position. But because of the inertia of the weight, the pendulum doesn't just stop at the equilibrium position. Instead, it continues swinging past it, back and forth. This motion is called **oscillation**. Eventually, friction with the air and the pivot point will cause the pendulum to come to a rest at the equilibrium position.

The pendulum model in this kit helps you to observe the angle of the robotic base unit relative to vertical. The pendulum will be pulled down by gravity, so even when the model is tilted, the pendulum should hang straight down toward the ground — unless the motion of the model has caused the pendulum to swing back and forth.

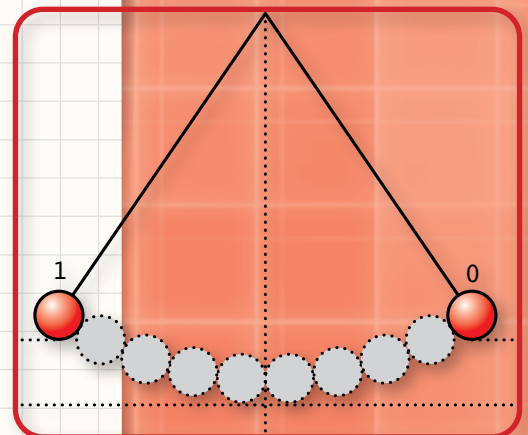



BALANCING BIRD

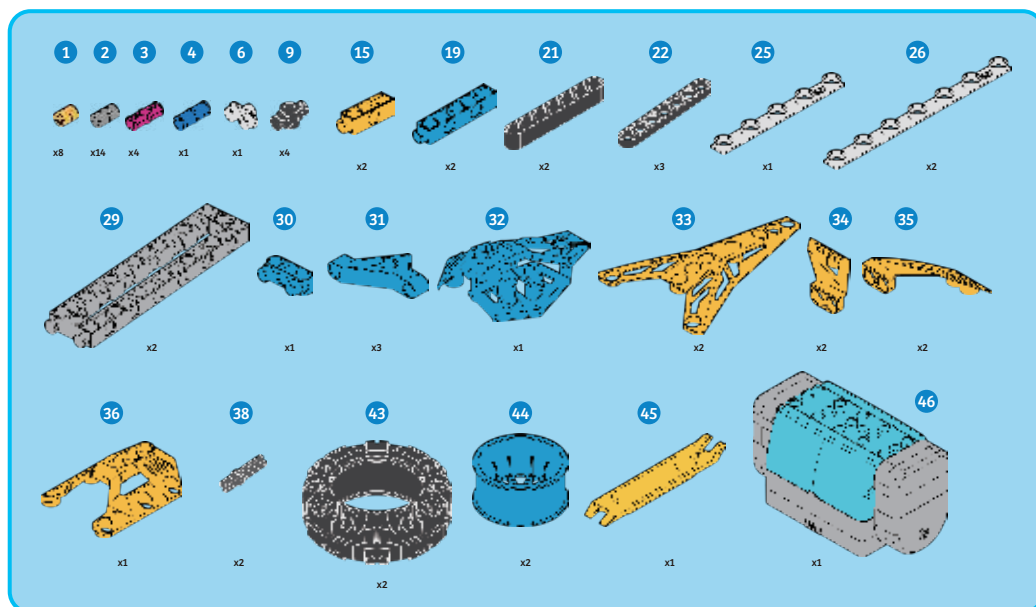

DIGITAL ASSEMBLY INSTRUCTIONS

Scan this QR code to open the product web page. Then, tap the link to access the digital assembly instructions app.

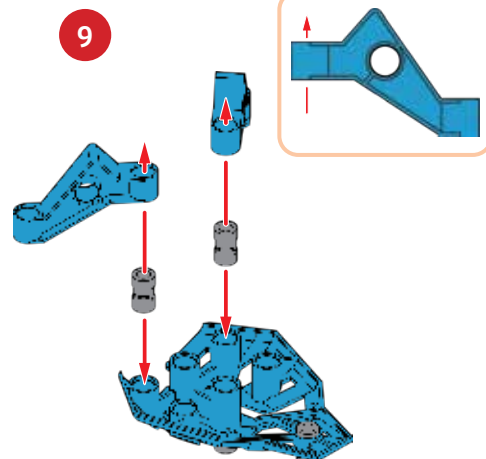
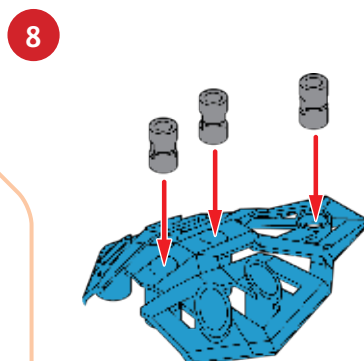
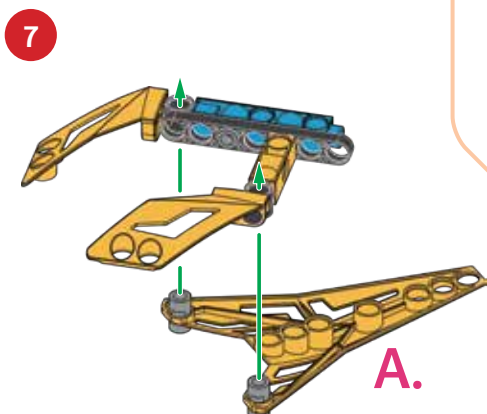
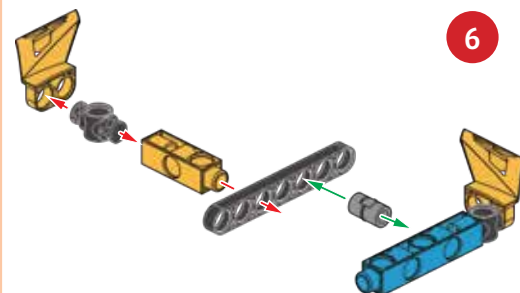
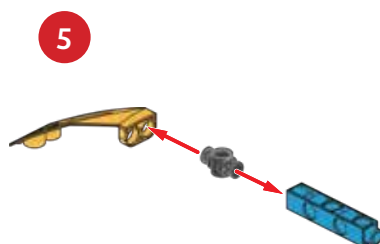
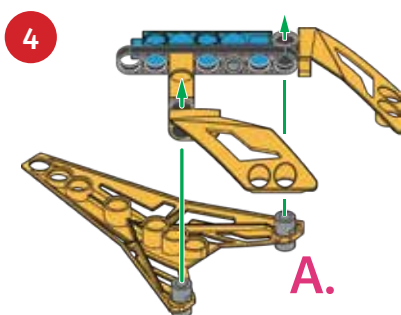
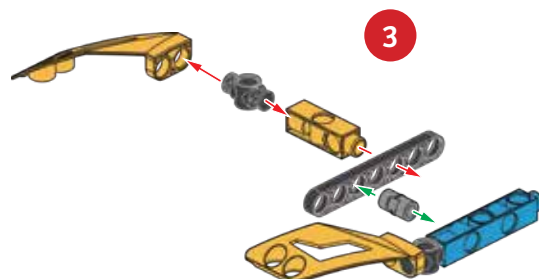
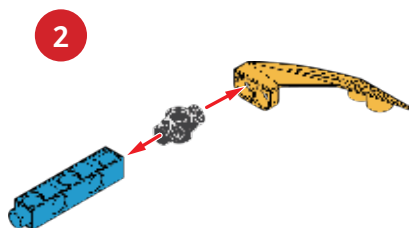
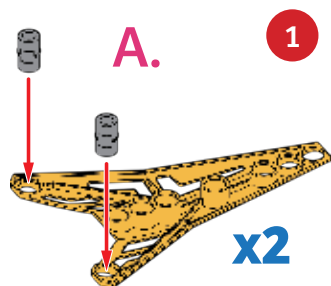



BALANCING BIRD

10

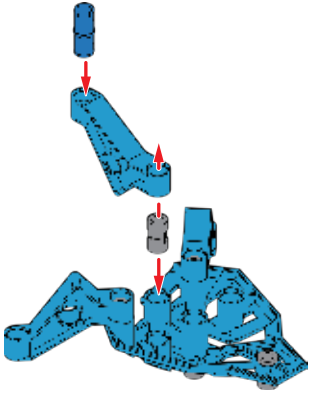

11

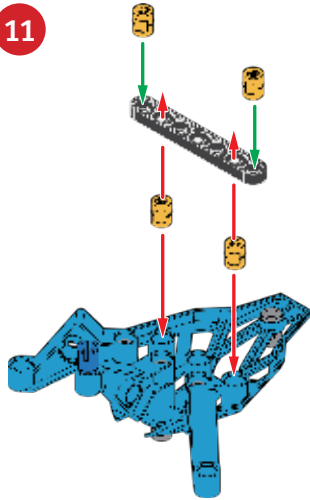

12

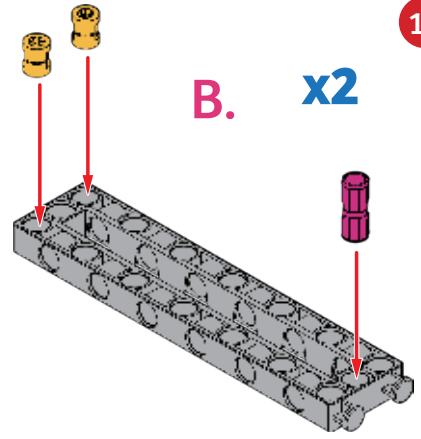

13

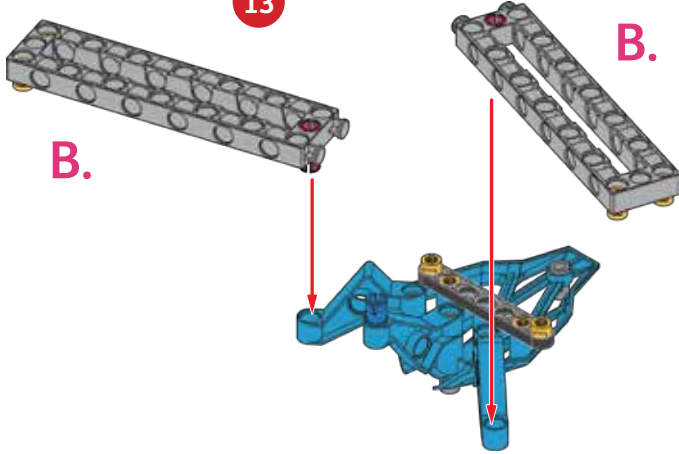

14

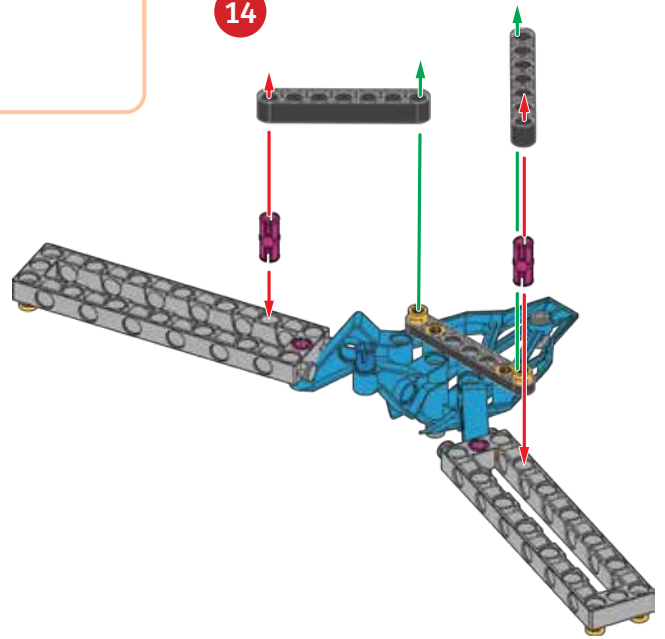

15

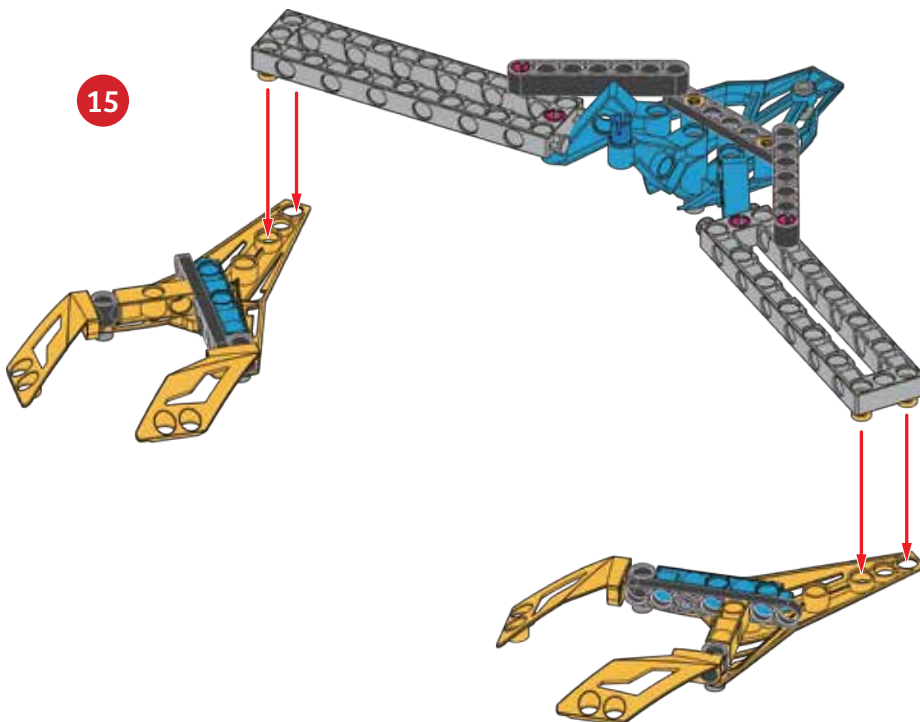

16

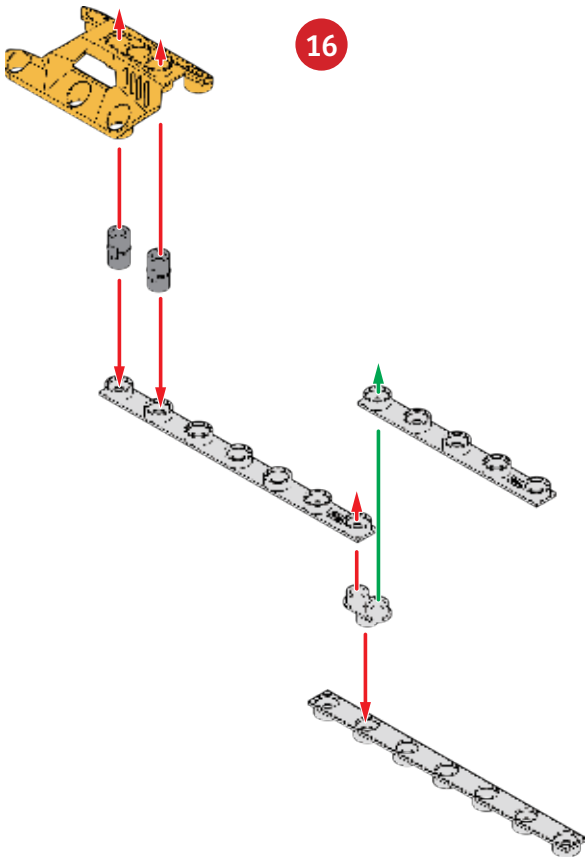

17

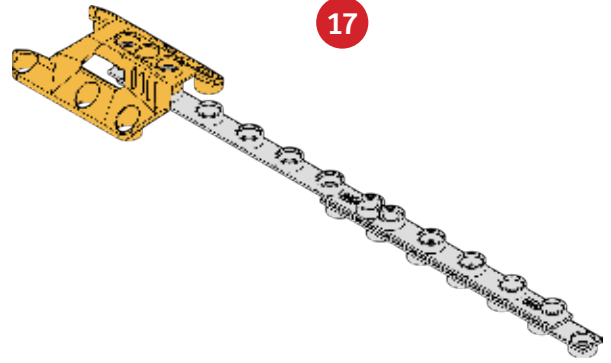

18

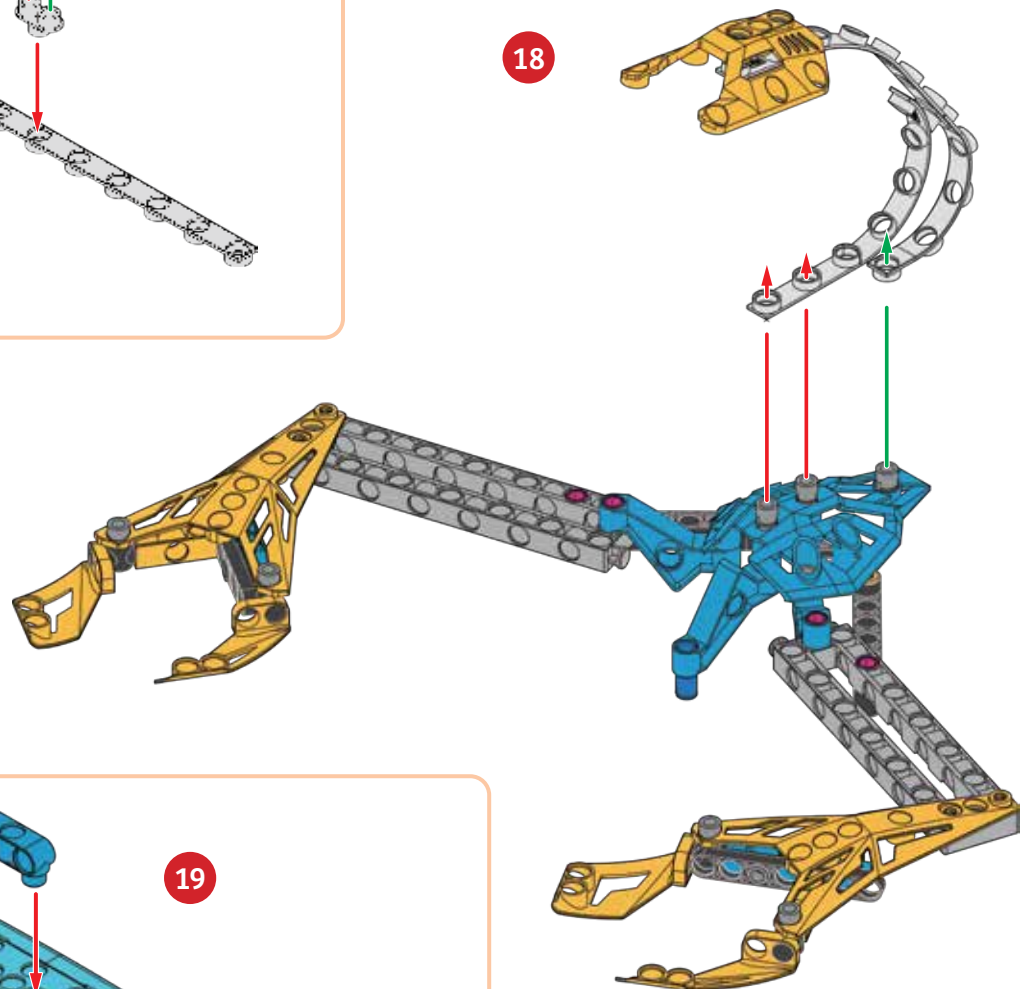

19

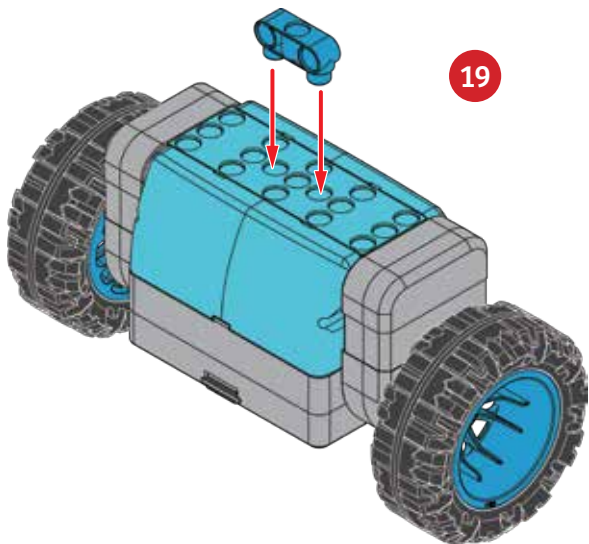



BALANCING BIRD

20

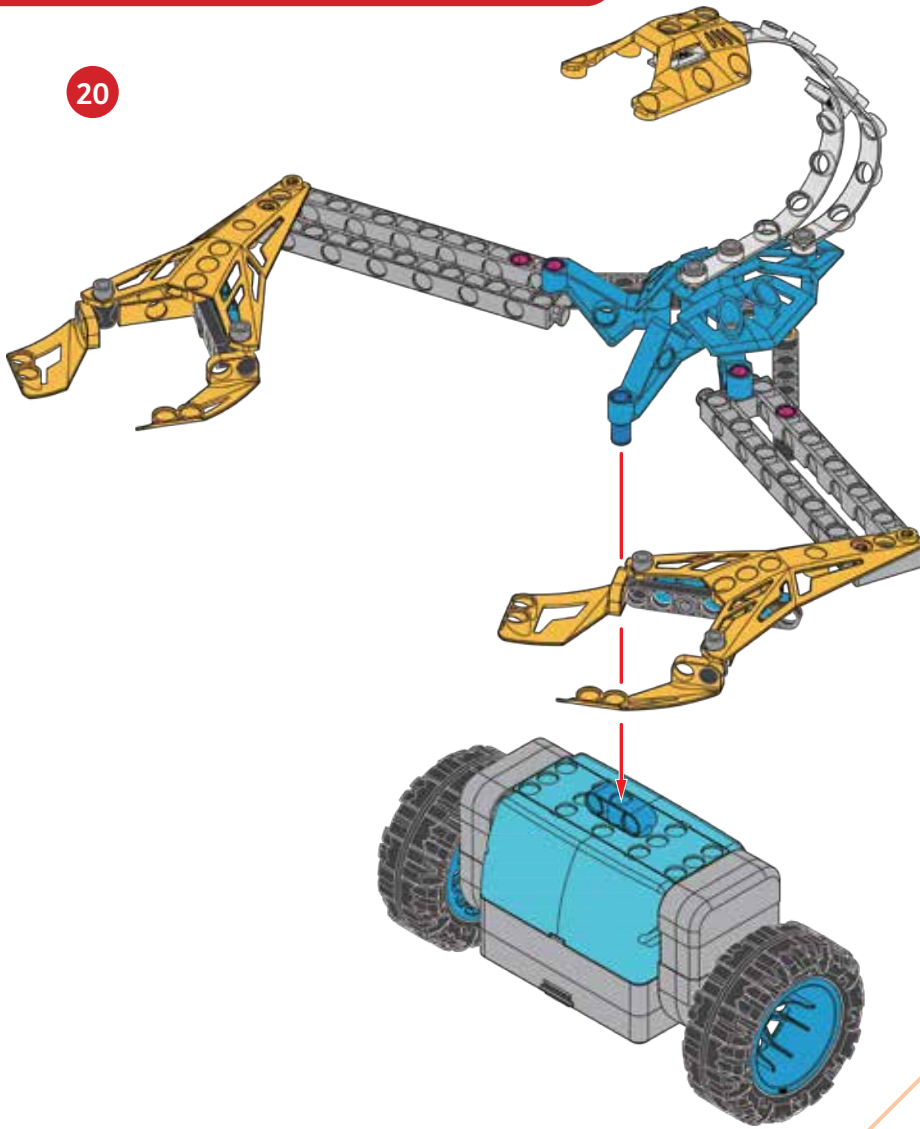

21

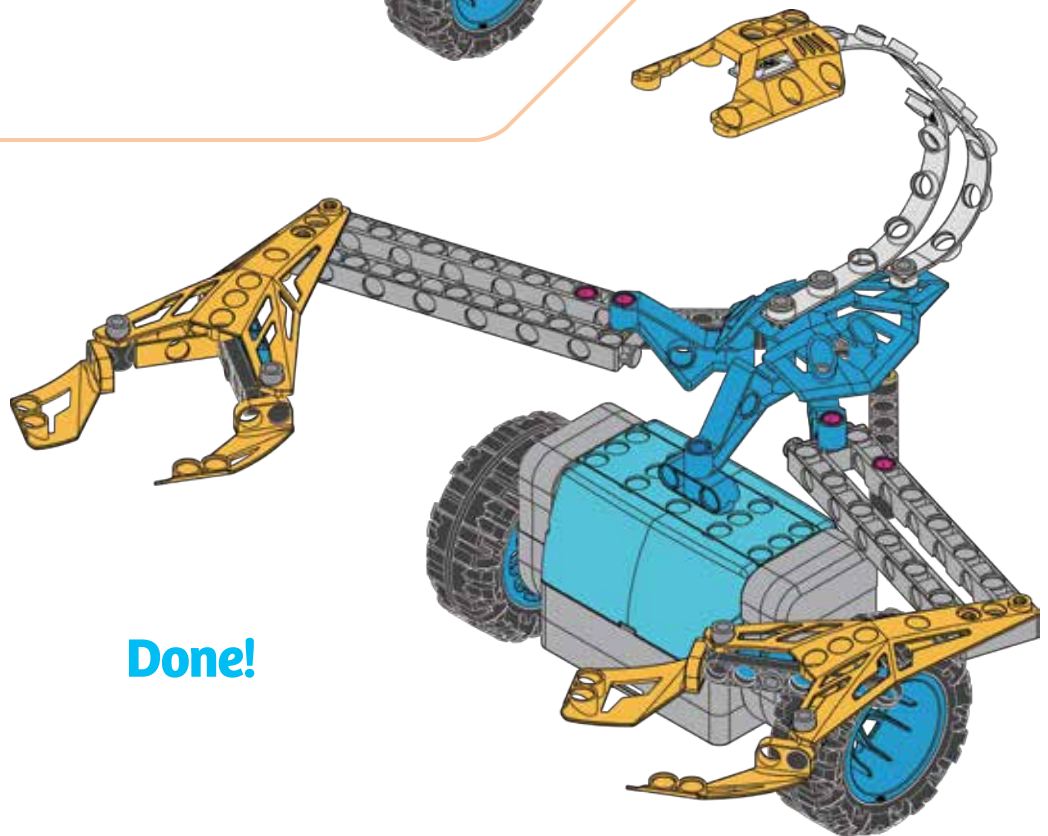

Done!

PROGRAMMING



SAMPLE PROGRAM FOR THE BALANCING BIRD

1. Assemble the model using the instructions on the previous pages. Put the model on the floor in an open area. Hold it upright and turn it on.
2. Establish the Bluetooth connection with the app. Open the **Balancing Bird** program. Note that the balance setting is set to **E**.
3. Press the run button. Hold the model until it is standing upright and balancing on its own. Observe the balancing bird's behavior as the robot runs the program. Below, write down what the robot does for each command step of the program.

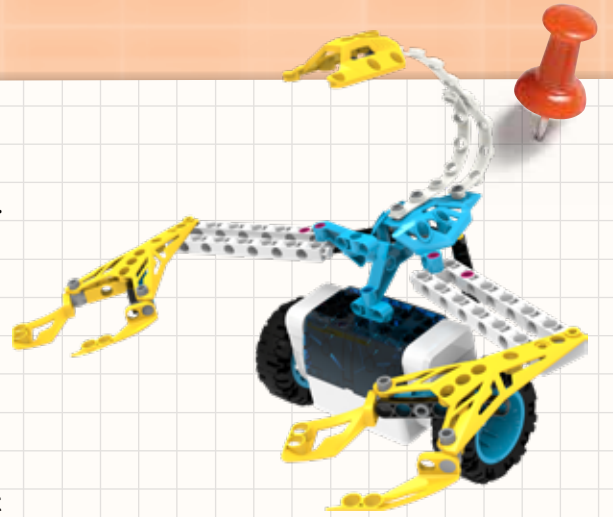

Balance Setting:

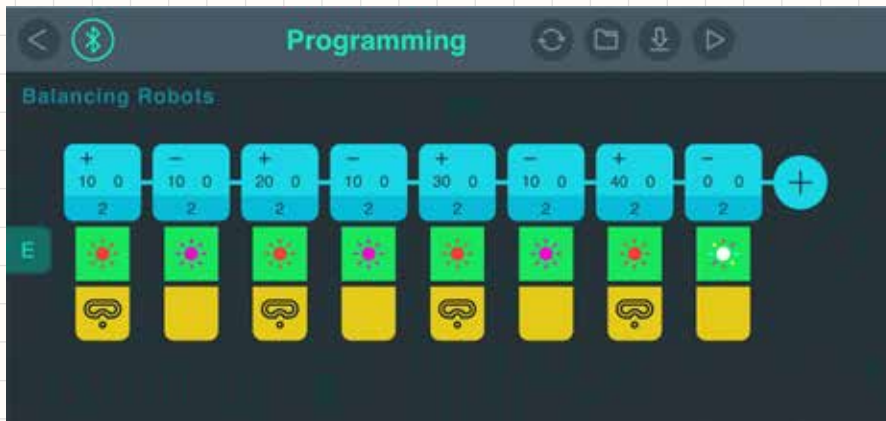

WHAT'S HAPPENING? *Record your observations here.*



CHECK IT OUT



The balancing bird model in this kit was inspired by the classic physics toy pictured here. The bird appears to “magically” balance on the tip of its beak. But it’s not magic that causes this. The bird is able to balance on its beak because its center of gravity is positioned exactly at its beak. Its wings and tail are weighted perfectly to result in the center point of all the weights being exactly at its beak.

What Is Balance?

Center of gravity is the point at which the entire weight of an object may be considered as concentrated so that if the object was supported at this point, the object would remain stationary in its current position. A body is stable if its center of gravity is located vertically above its base of support. Then, it is in a state of **stable equilibrium**.

If its center of gravity lies vertically above its **tipping line** (the edge of the base), then it will wobble or tilt. The slightest movement will make it tip over. But its steadiness will also depend on the force needed to push it off balance, as well as on the base on which it supports itself. In the case of a car, the four wheels resting on the pavement form a rectangle. That is its base of support.

The two-wheeled balancing robot models in this kit are not stable on their own — without the constant adjustments made by the motion of the wheels, the robots would stay standing upright. They would fall over.



ROBOTIC WAITER

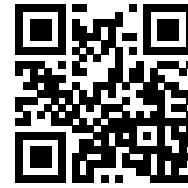
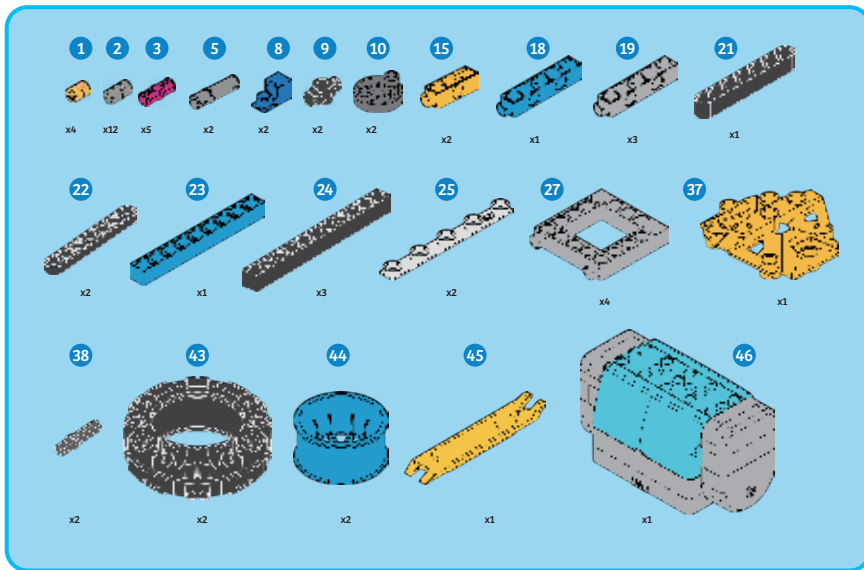

DIGITAL ASSEMBLY INSTRUCTIONS

Scan this QR code to open the product web page. Then, tap the link to access the digital assembly instructions app.

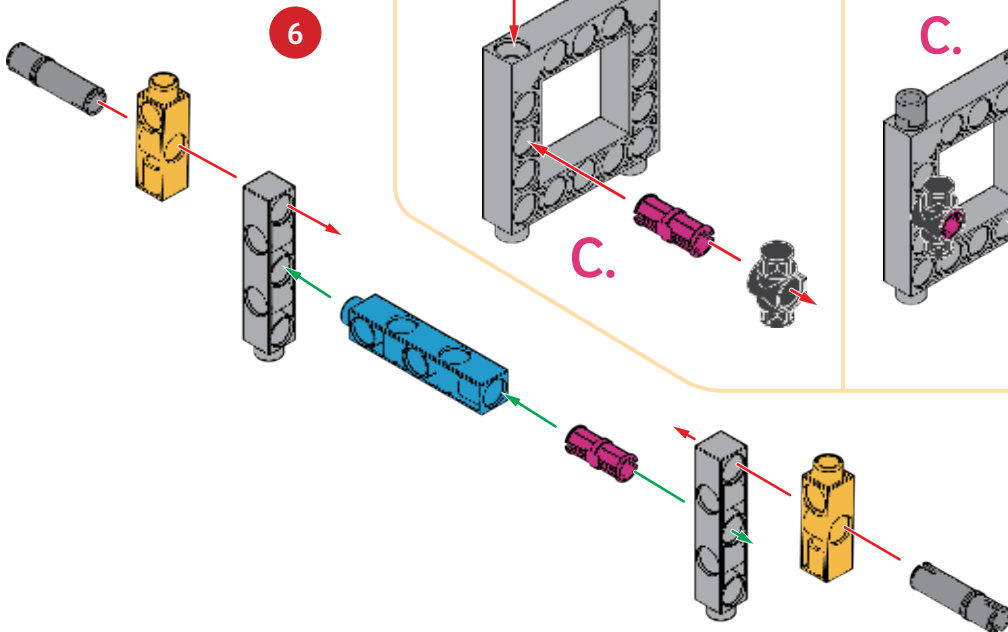
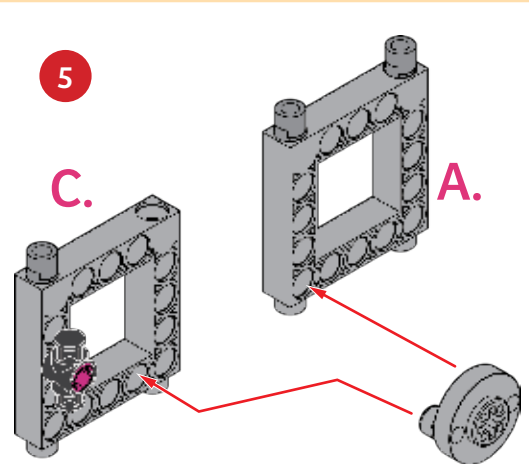
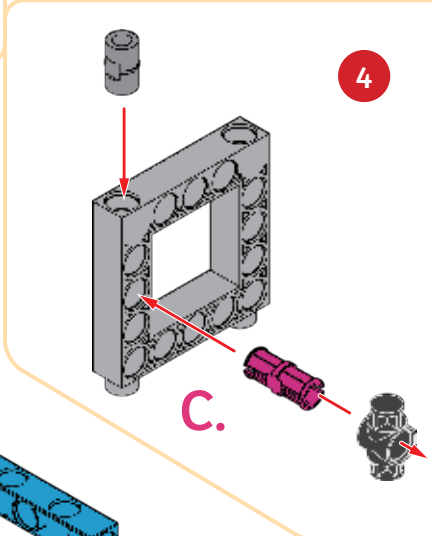
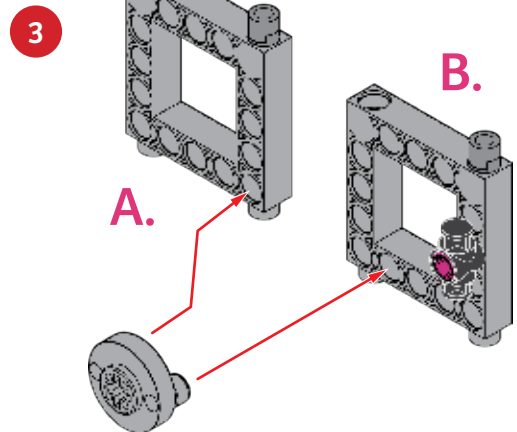
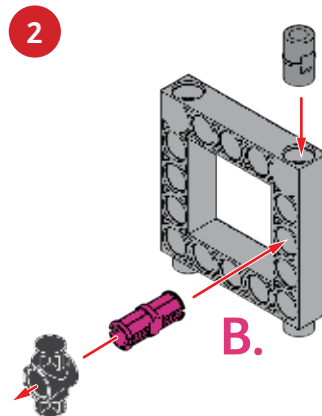
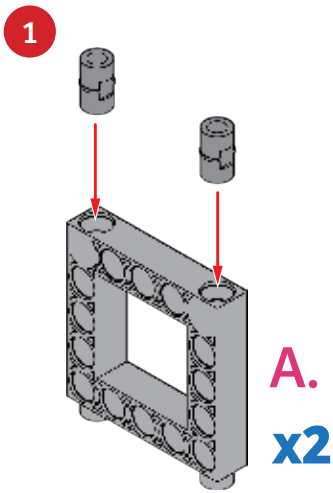



7

B.

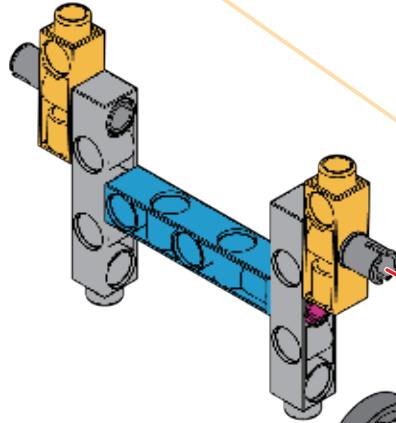
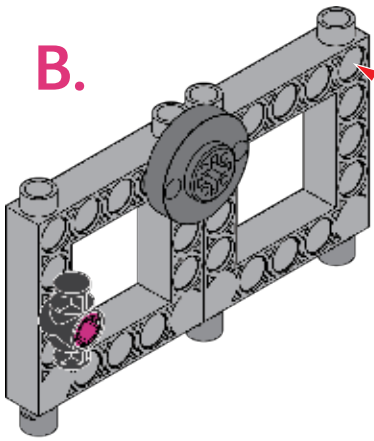

C.

8

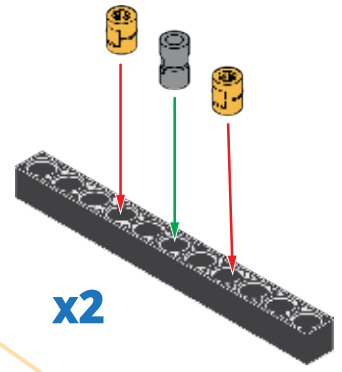

9

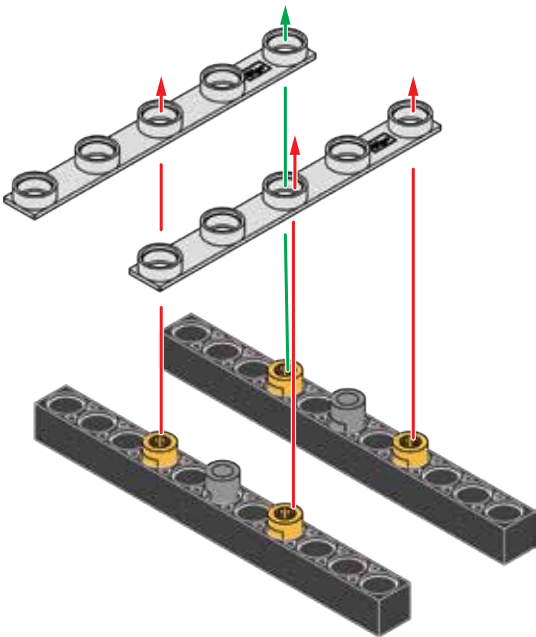

10

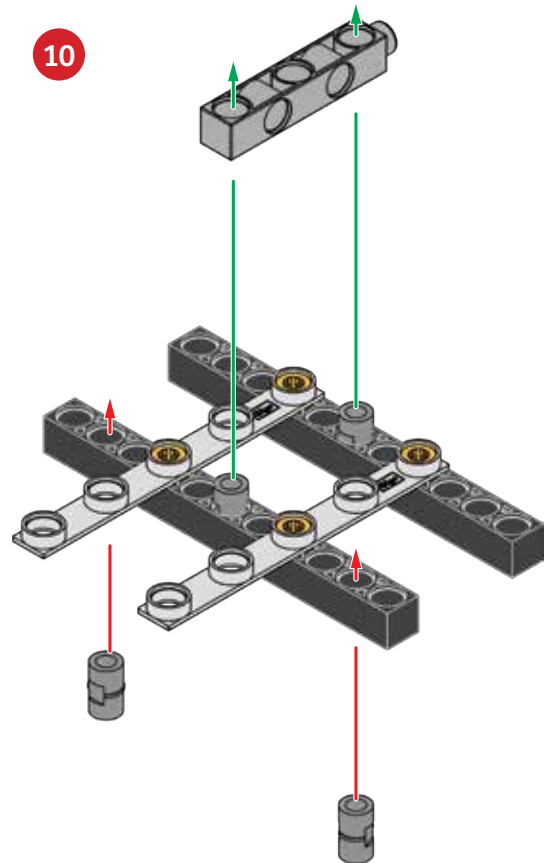

11

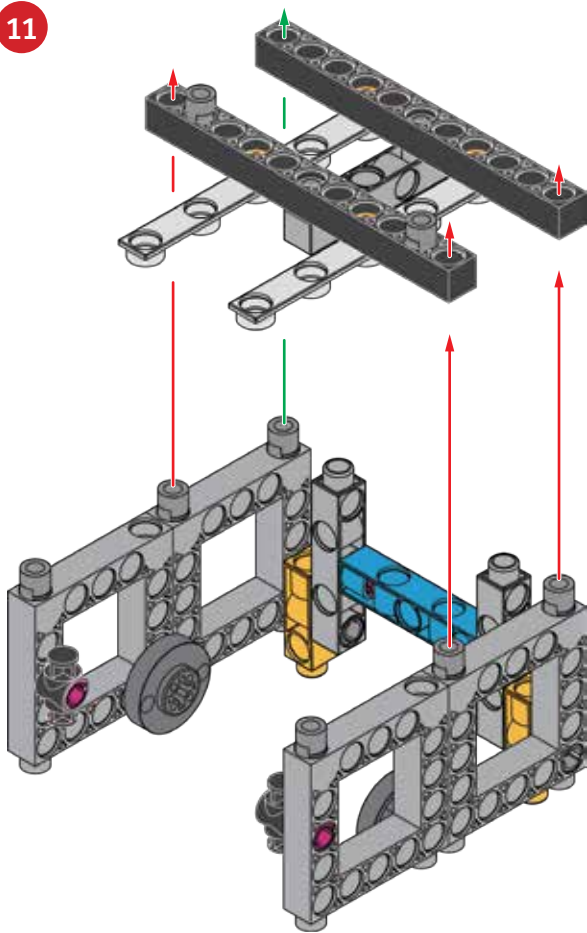

12

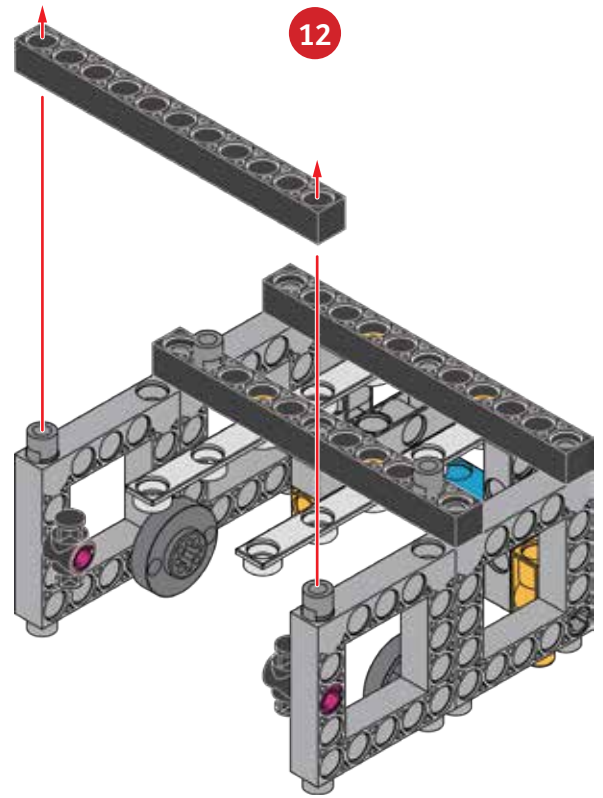

13

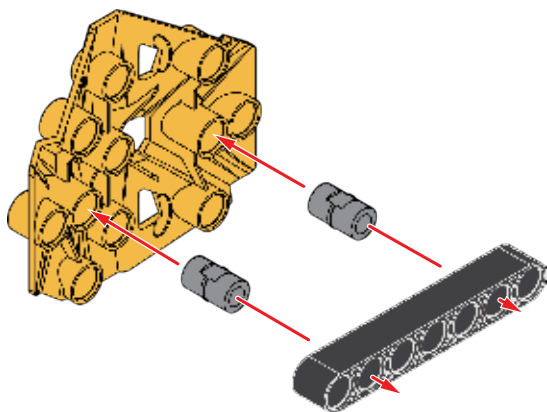

14

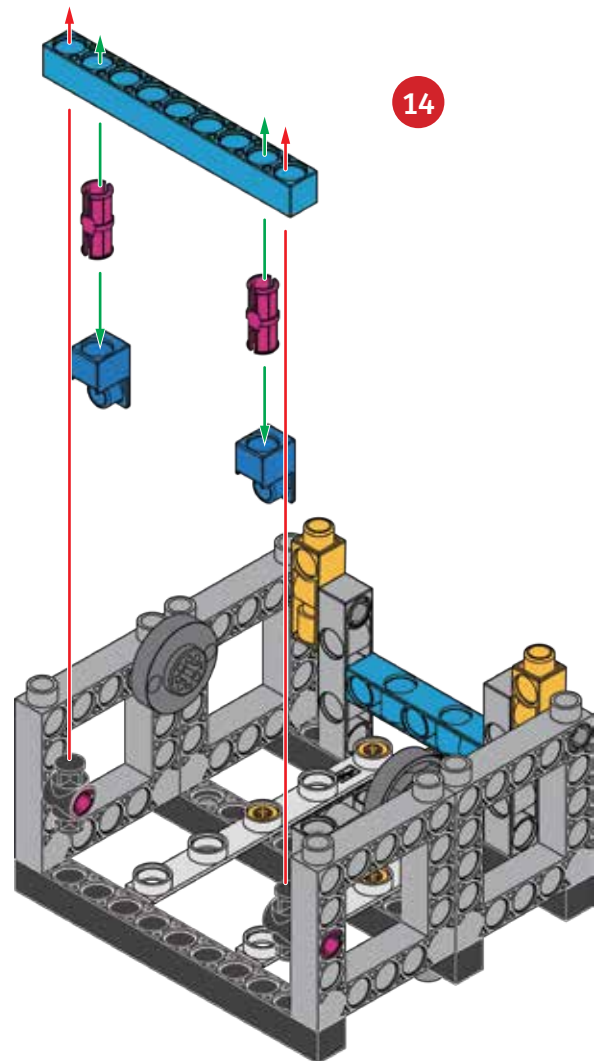



15

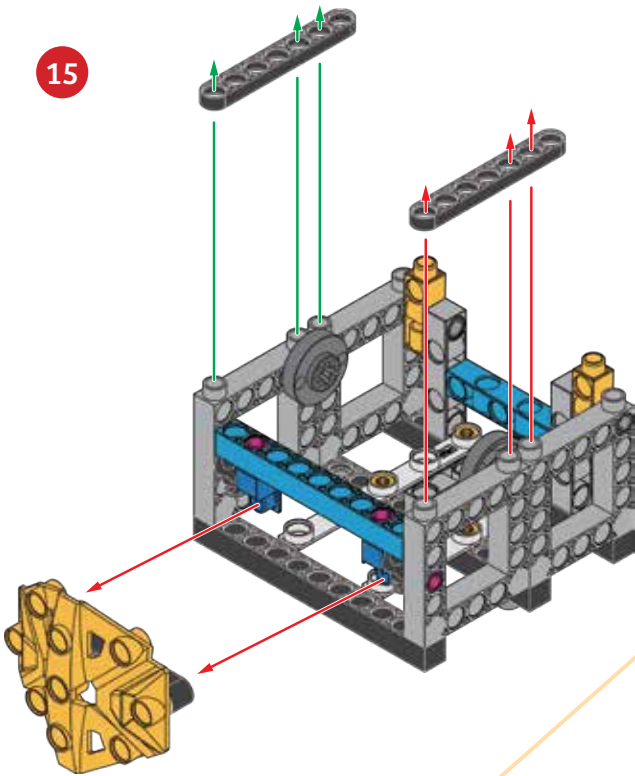

16

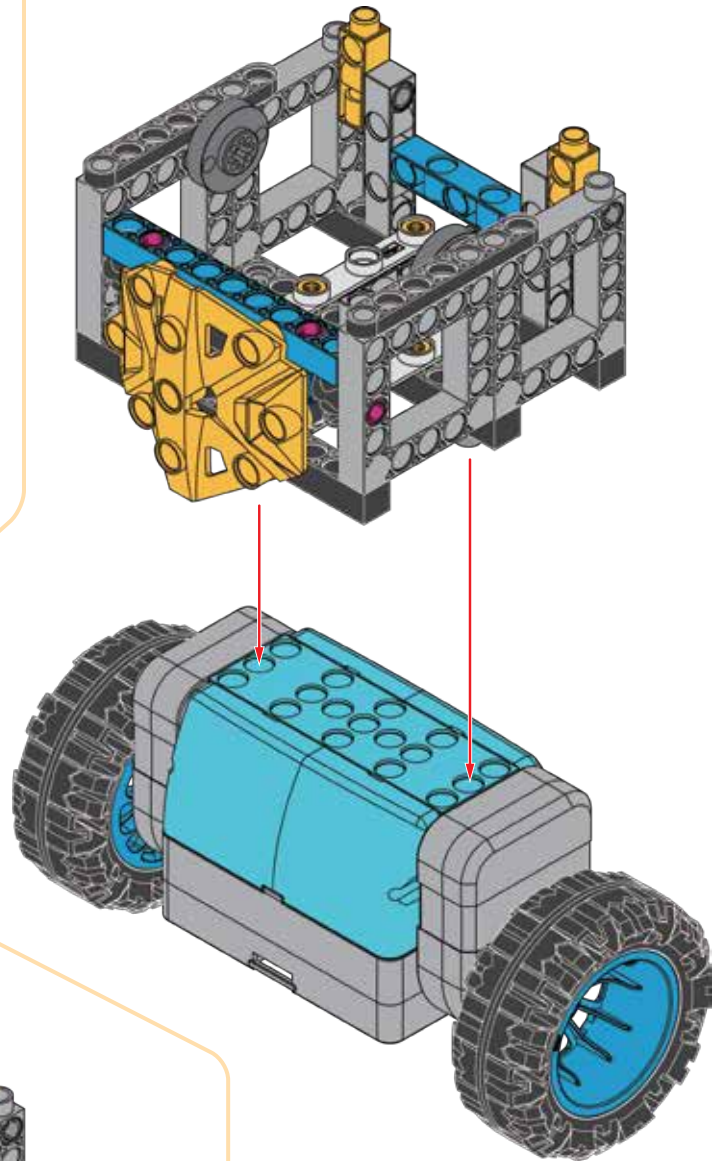

17

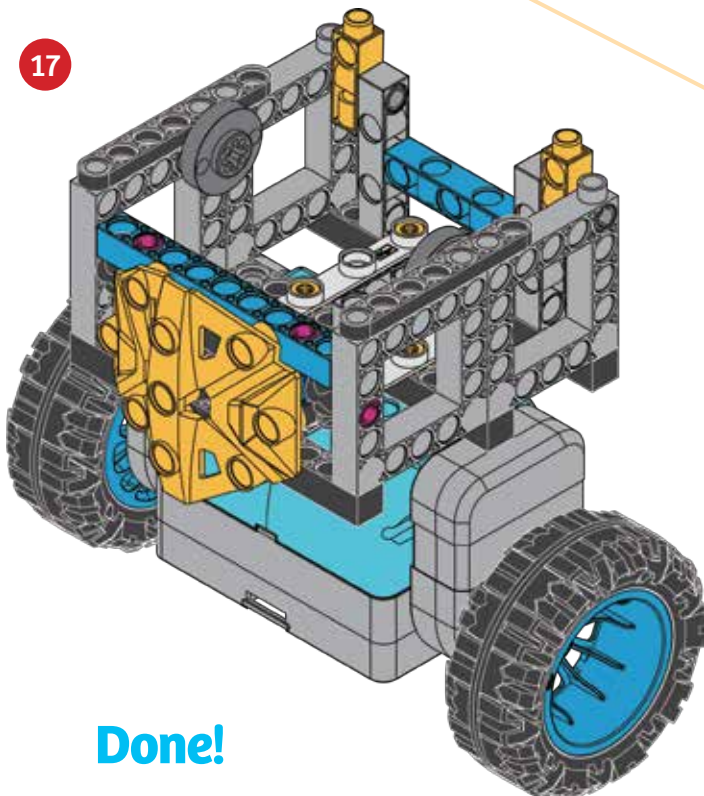

Done!

PROGRAMMING



SAMPLE PROGRAM FOR THE ROBOTIC WAITER

1. Assemble the model using the instructions on the previous pages. Put the model on the floor in an open area. Hold it upright and turn it on.
2. Establish the Bluetooth connection with the app. Open the **Robotic Waiter** program. Note that the balance setting is set to **F**.
3. Press the run button. Hold the model until it is standing upright and balancing on its own. Place a cup or a beverage can in the waiter's basket. (Do not use a cup with liquid in it or an open beverage can.) Below, write down what the robot does for each command step of the program. Can you add more command steps to the program to deliver the cup or can from one place to another?

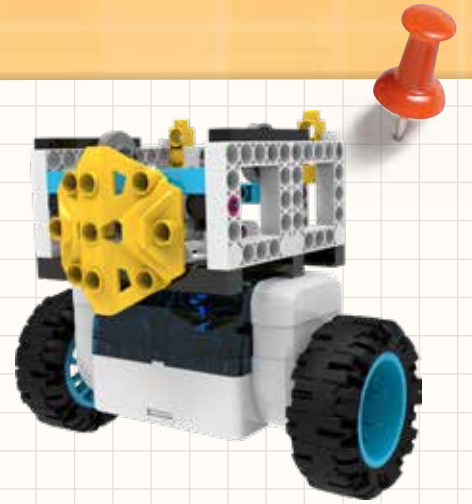

Balance
Setting:

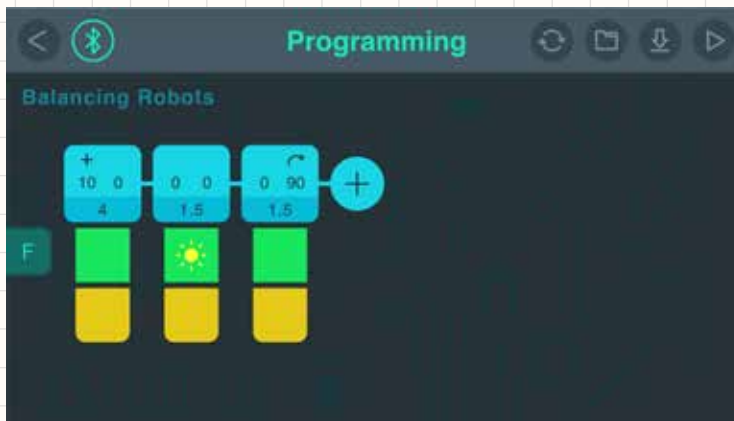

WHAT'S HAPPENING? Record your observations here.



CHECK IT OUT



Helpful Robots

Wouldn't you love to have a robotic waiter who could pick up the clothes in your room and put them in the closet or bring you an ice cream sundae when you want one? Well, most people don't have sophisticated robotic waiters in their homes today, but as technology gets more affordable and widely available, we will likely start seeing more and more personal assistant robots that can help make humans' lives easier.



Today, robots are being used to pick, move, and pack goods in high-tech warehouses. Like your balancing waiter robot, these robots need to move objects without tipping over. Their short, squat designs and wide-set wheels make them very stable and unlikely to tip over. They are optimized for stability over speed.



In the future, packages might be delivered to you by flying drone robots. These also use sophisticated balancing technologies to stay in the air.



TARGET PRACTICE ROBOT

1 x14, 2 x7, 3 x4, 13 x4, 16 x1, 26 x1, 28 x2, 29 x2, 33 x1, 34 x2, 35 x2, 36 x2

+ Robotic Waiter model

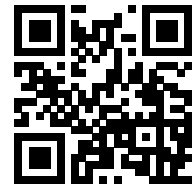

DIGITAL ASSEMBLY INSTRUCTIONS

Scan this QR code to open the product web page. Then, tap the link to access the digital assembly instructions app.

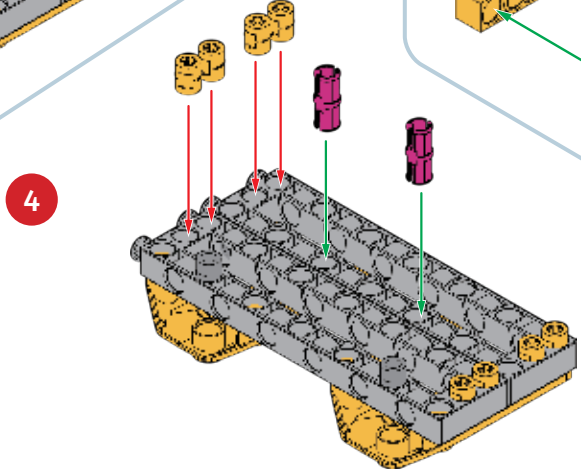
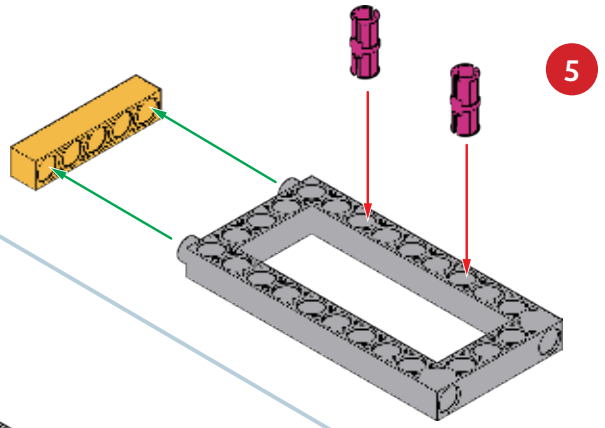
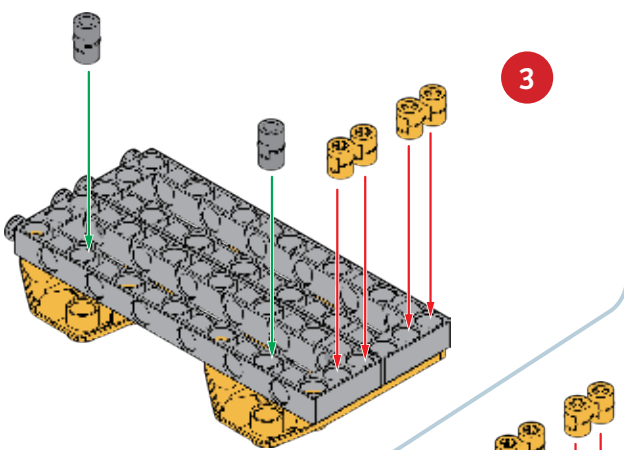
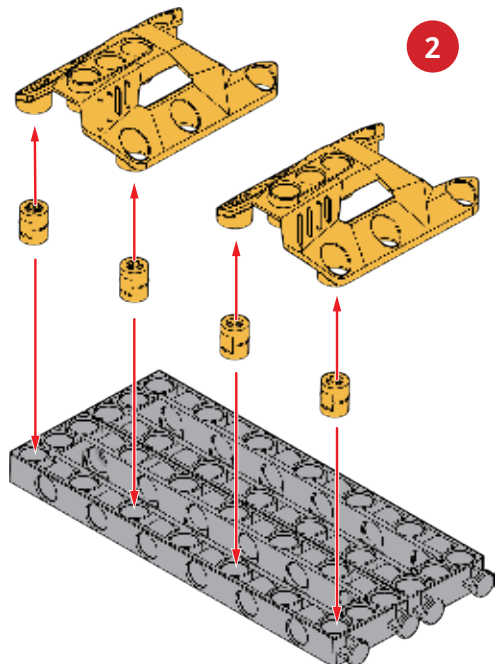
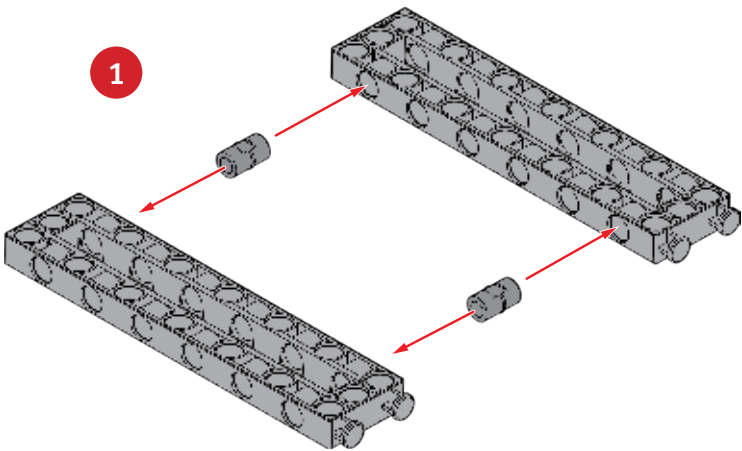



6

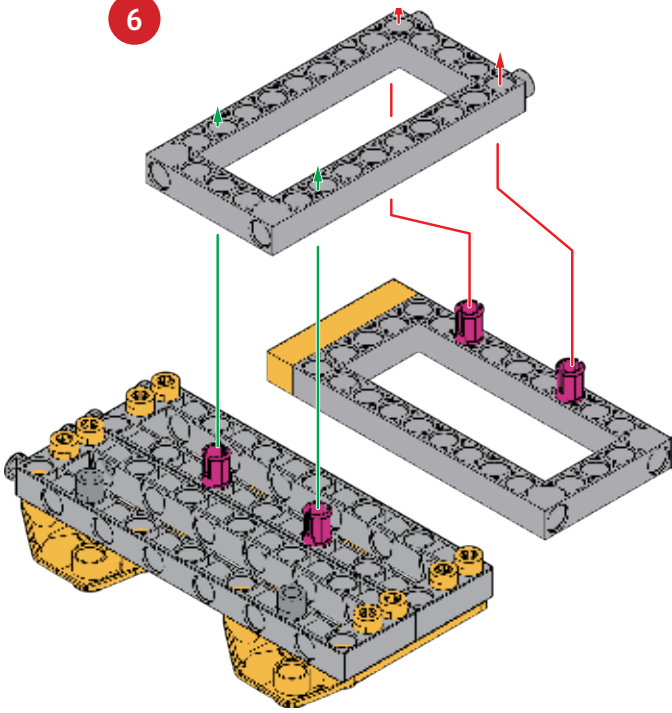

7

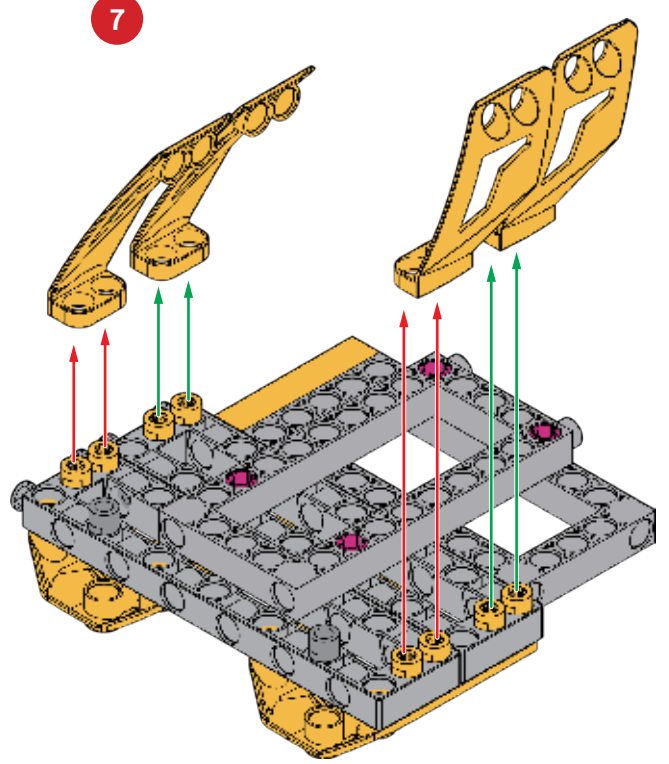

8

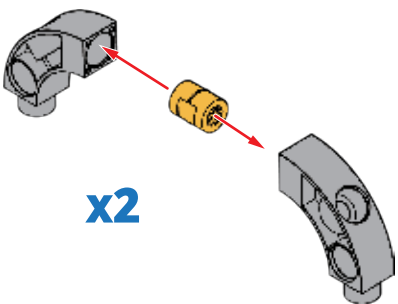

9

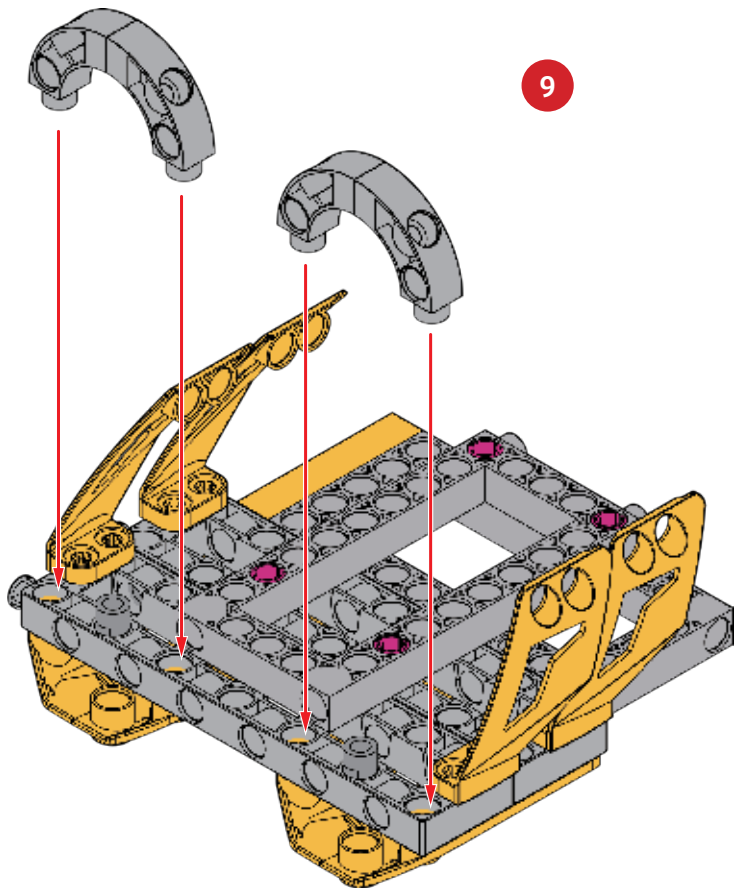

10

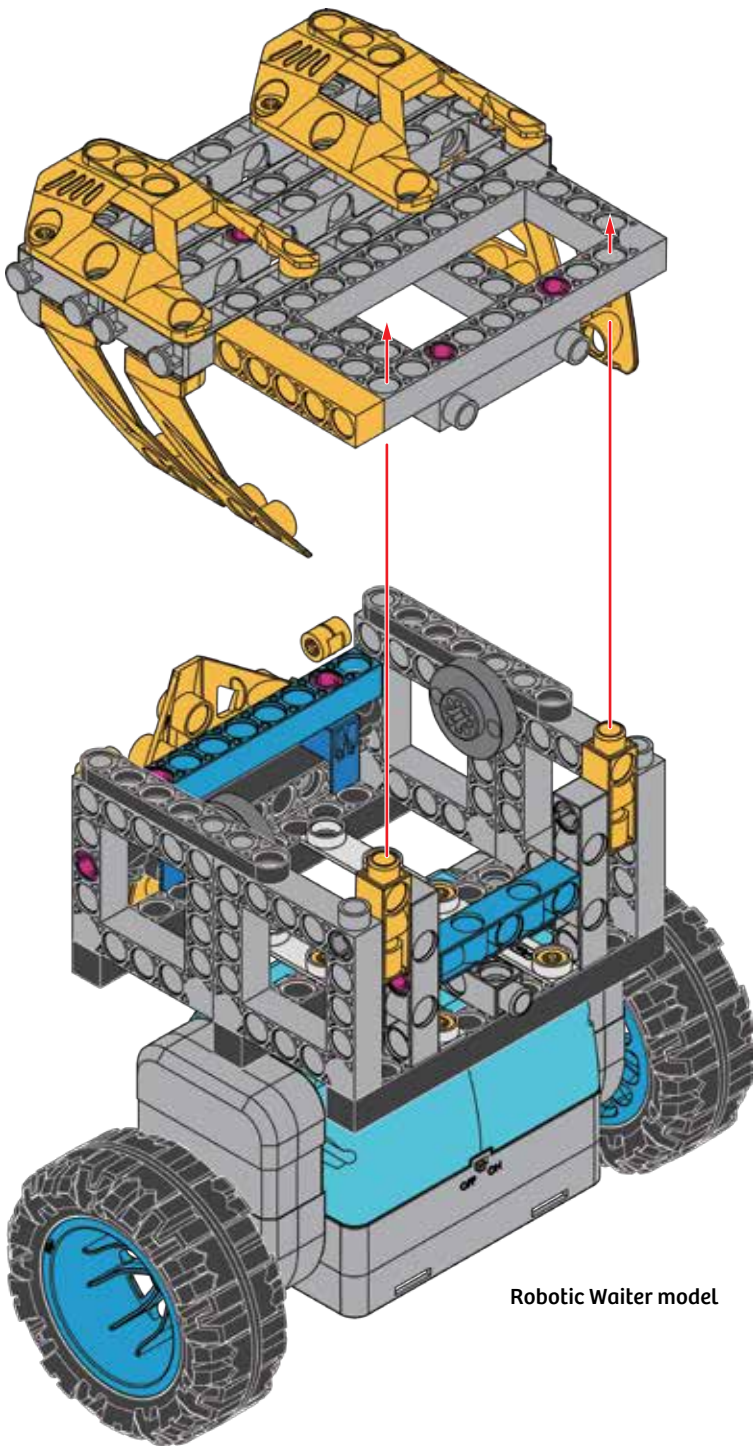

Robotic Waiter model

11

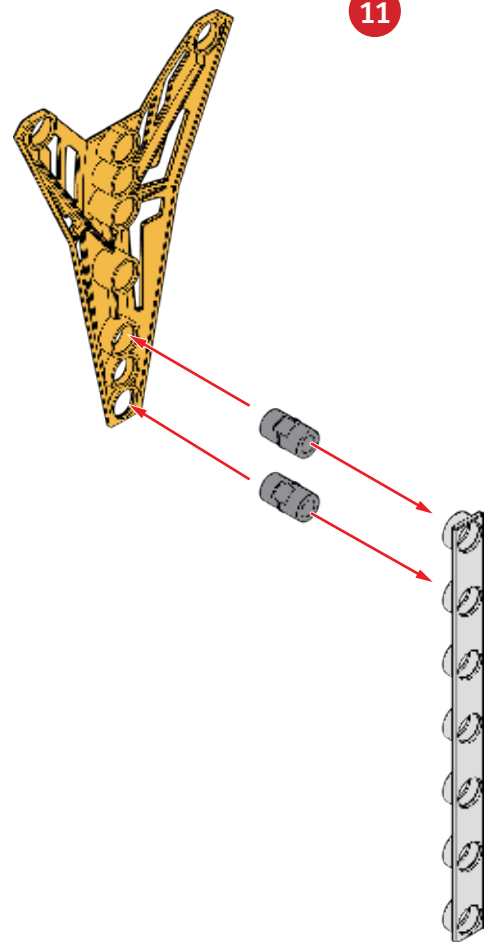



12

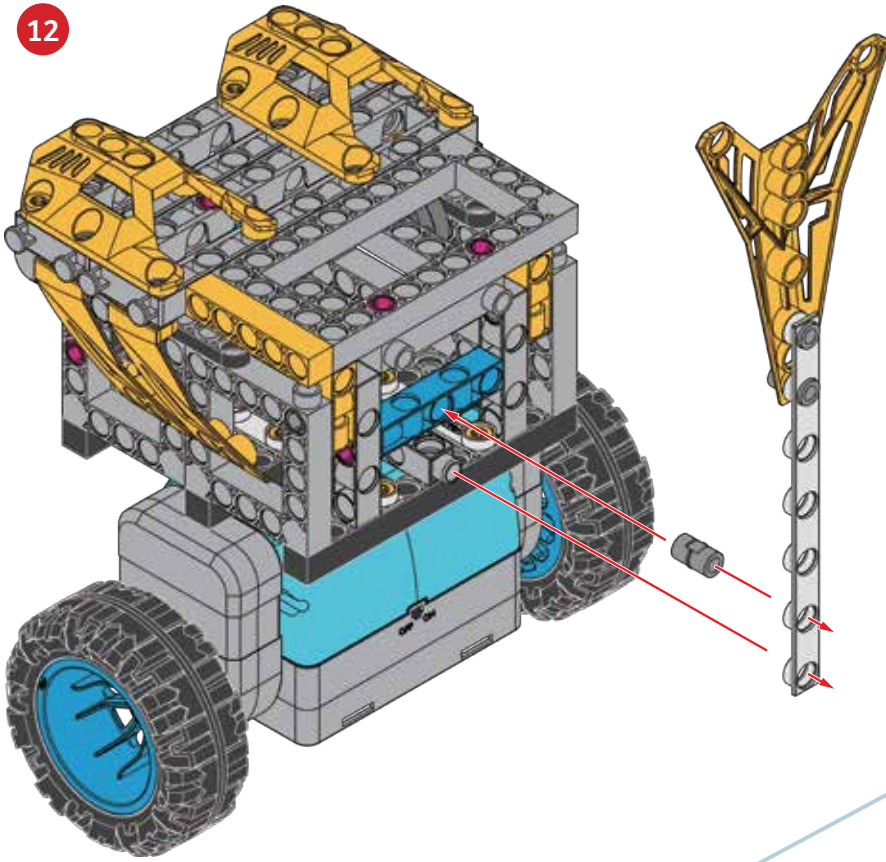

13

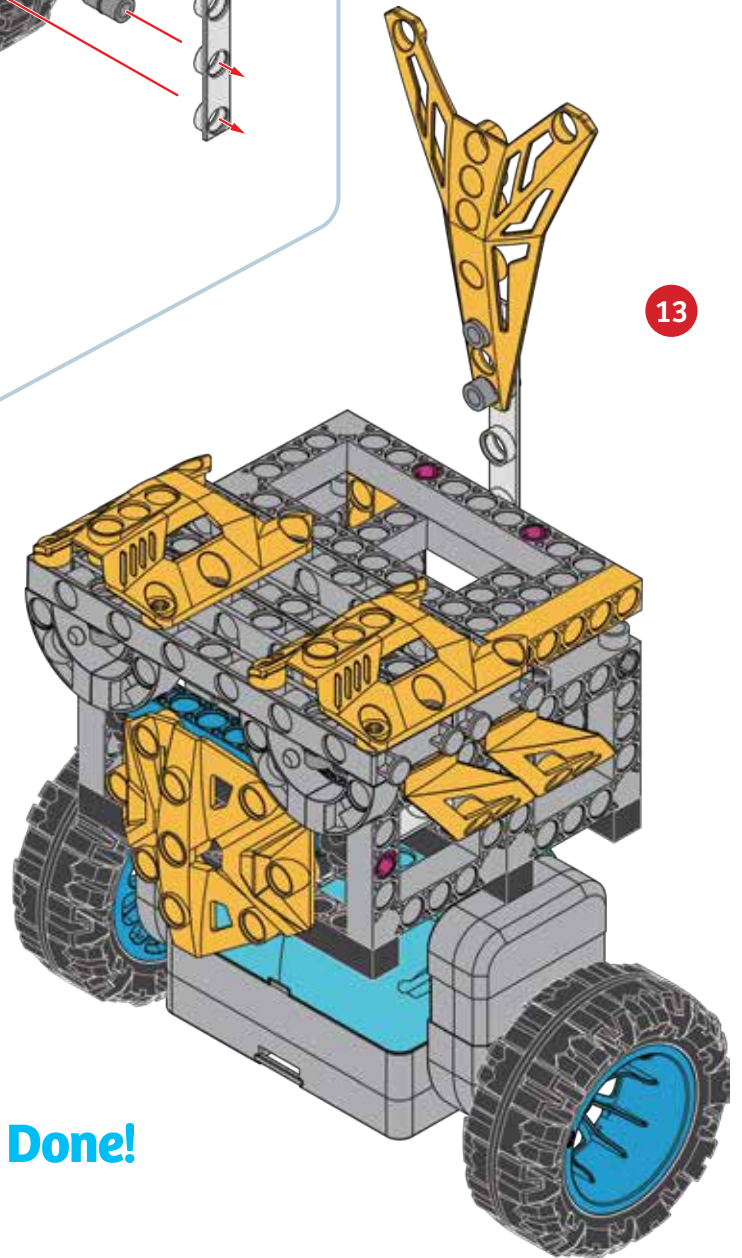

Done!

PROGRAMMING



SAMPLE PROGRAM FOR THE TARGET PRACTICE ROBOT

1. Assemble the model using the instructions on the previous pages. Put the model on the floor in an open area. Hold it upright and turn it on.
2. Establish the Bluetooth connection with the app. Open the **Target Practice Robot** program. Note that the balance setting is set to **G**.
3. Press the run button. Hold the model until it is standing upright and balancing on its own. Toss crumpled up paper balls at the robot and try to hit the vertical target. Is it able to stay balanced? Below, write down what the robot does for each command step of the program. Can you add more command steps to the program to make the robot move around more and make the target harder to hit?

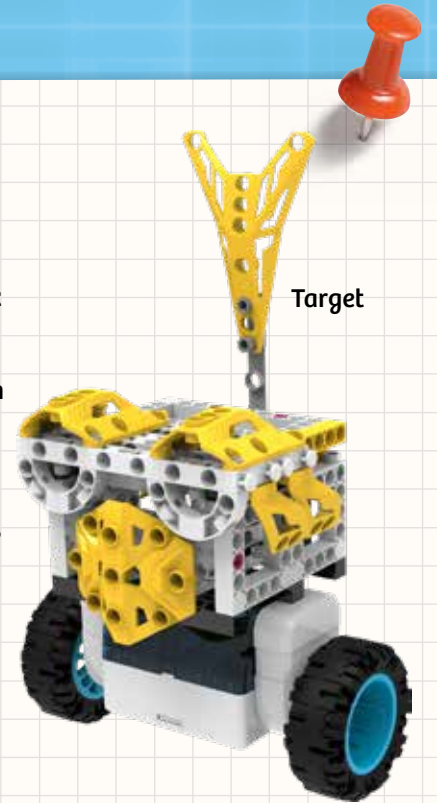

Target

Balance Setting:

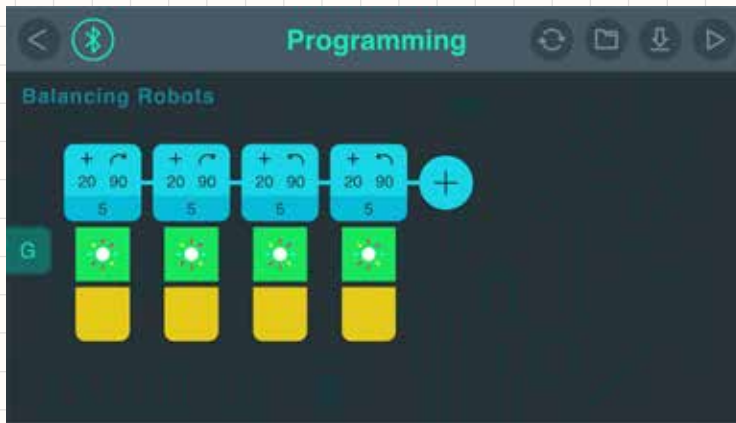

WHAT'S HAPPENING? *Record your observations here.*



CHECK IT OUT

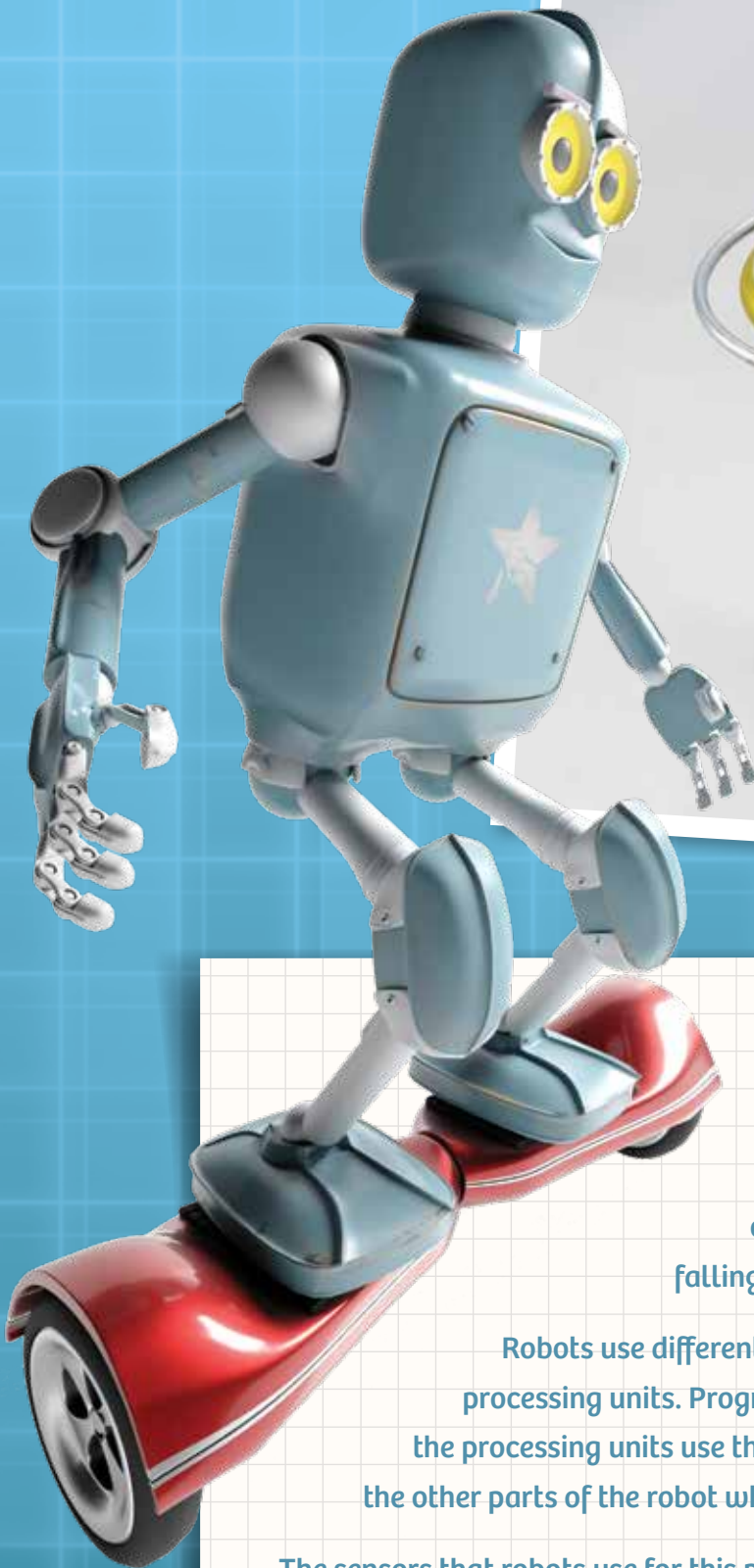

A **gyroscope** is a device consisting of a spinning wheel mounted in a frame that allows the wheel to spin freely in any orientation. They are used for measuring orientation and angular (or rotating) velocity.

Self-Balancing Robots

How does a robot know its position and orientation in space? How does it know if it is falling over and in what direction?

Robots use different types of **sensors** to provide data to their processing units. Programs written by engineers that are running on the processing units use this data to determine instructions to command the other parts of the robot what to do based on the data.

The sensors that robots use for this purpose include: **gyroscope sensors**, which tell the robot its relative position and angle in space; **accelerometers**, which tell the robot if its speed and direction are changing; **radar, sonar, and lidar** sensors, which tell the robot its position relative to other objects; and **GPS**, which tells the robot its location relative to satellites orbiting Earth and thus its precise location on Earth.

BALANCING DINO ROBOT

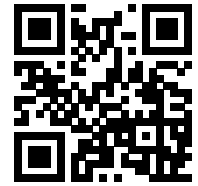
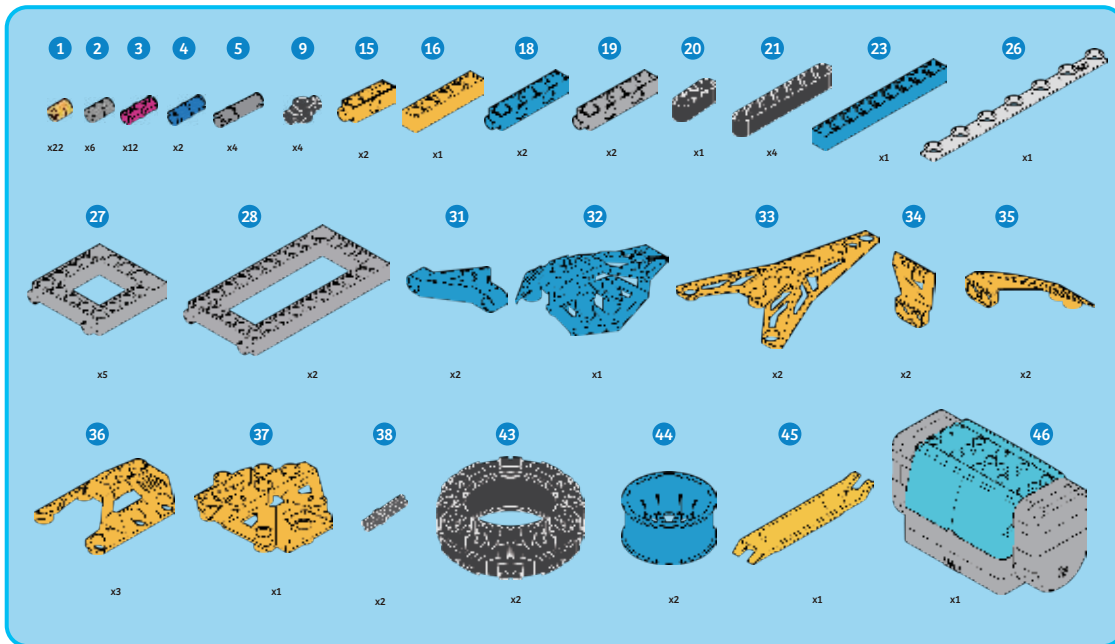

DIGITAL ASSEMBLY INSTRUCTIONS

Scan this QR code to open the product web page. Then, tap the link to access the digital assembly instructions app.

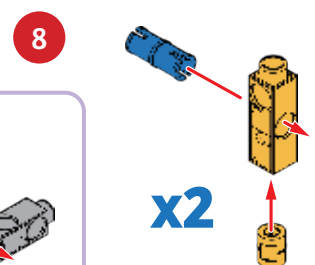
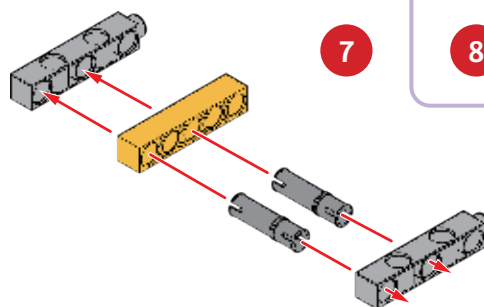
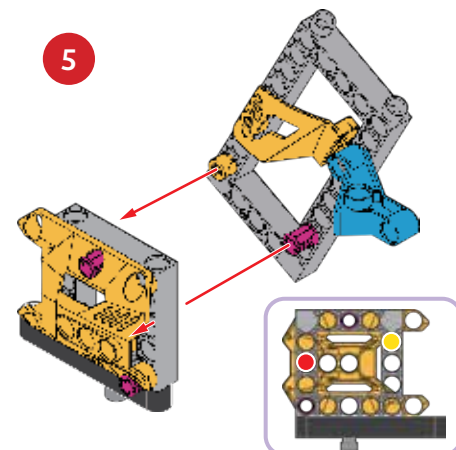
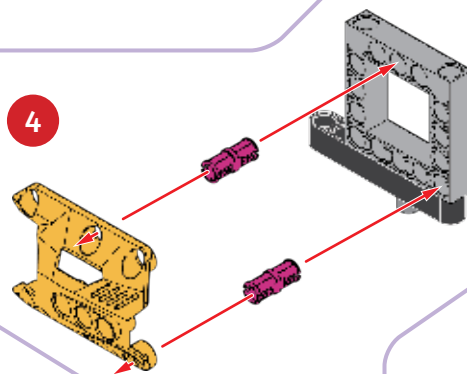
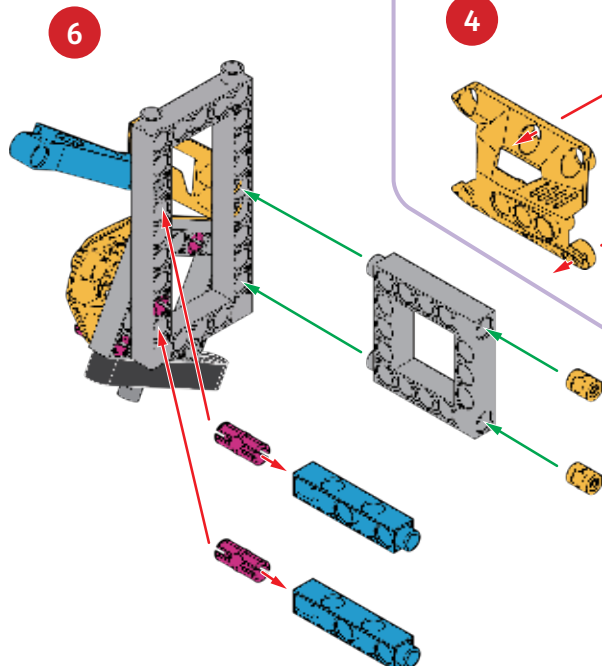
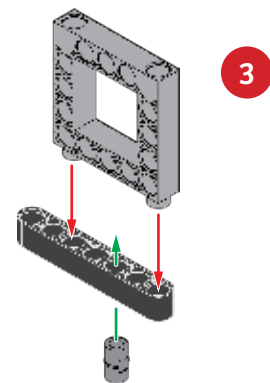
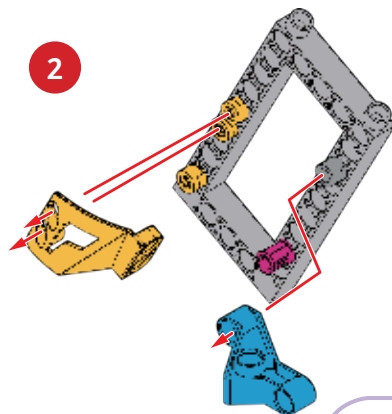
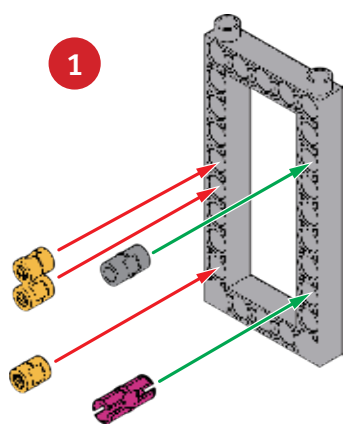



BALANCING DINO ROBOT

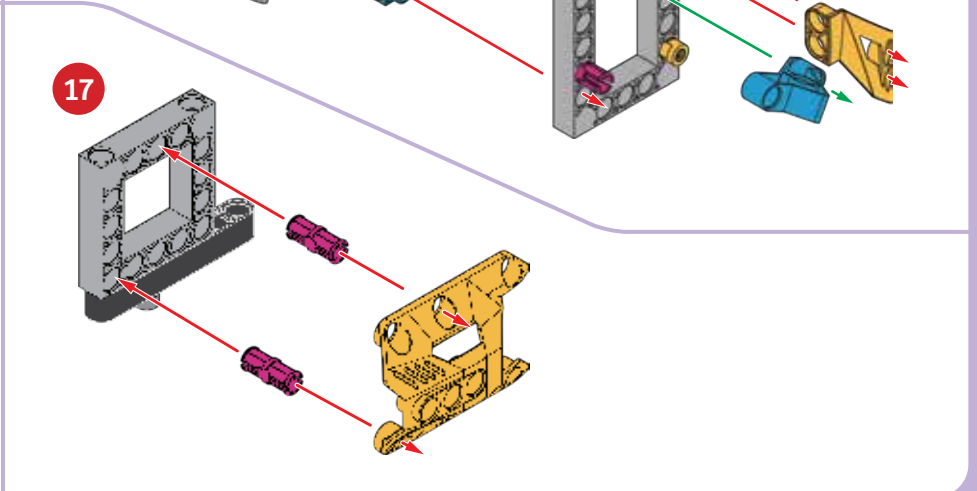
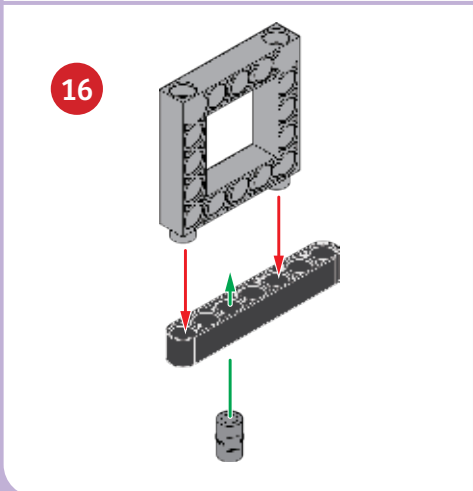
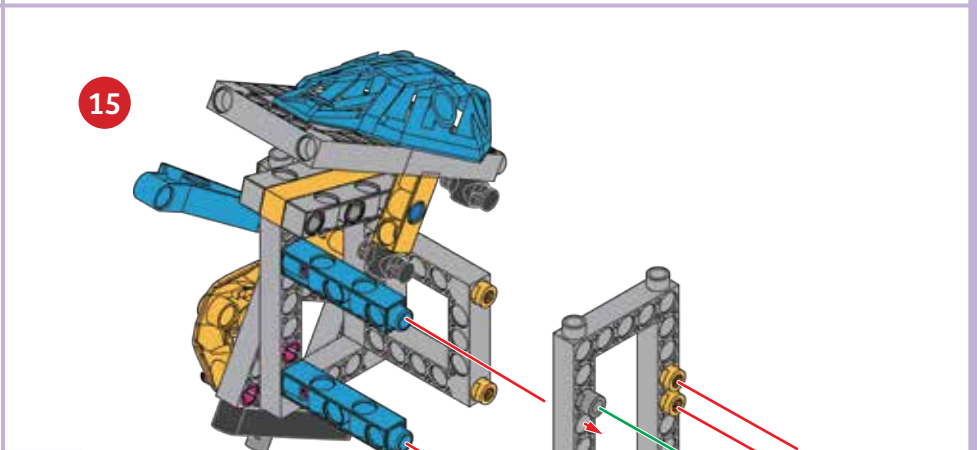
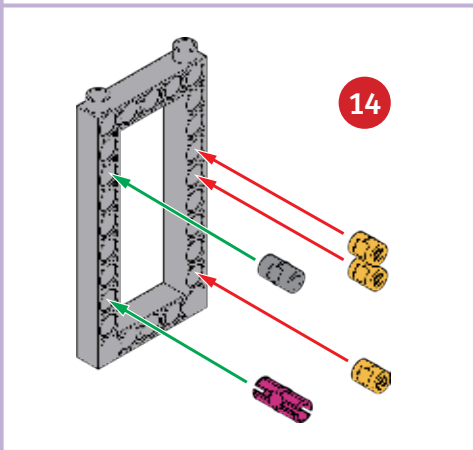
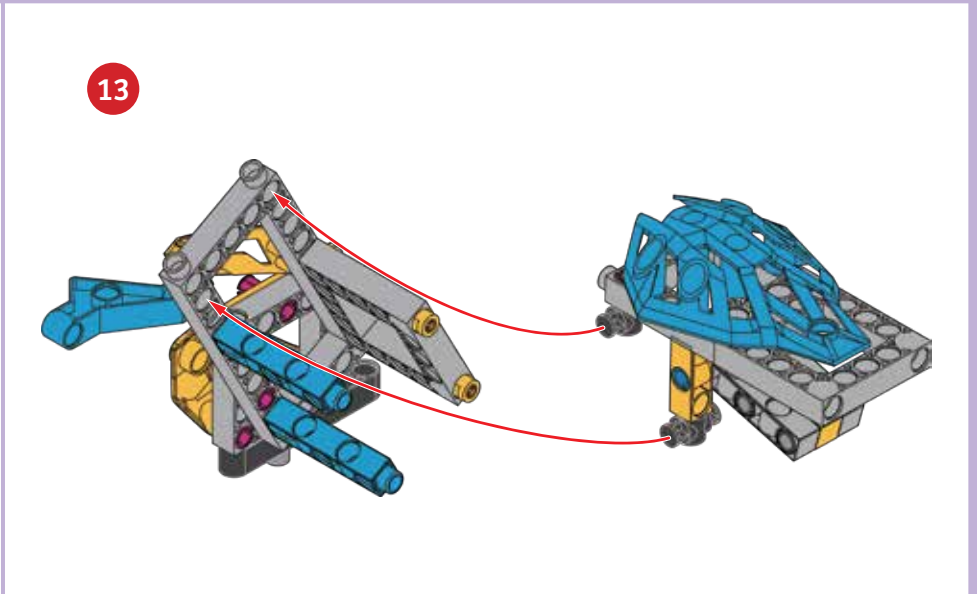
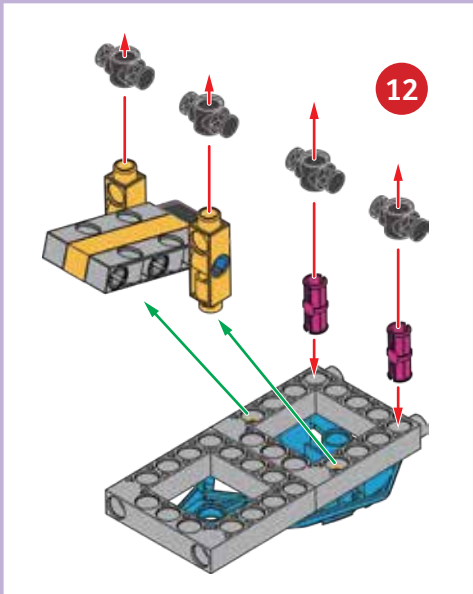
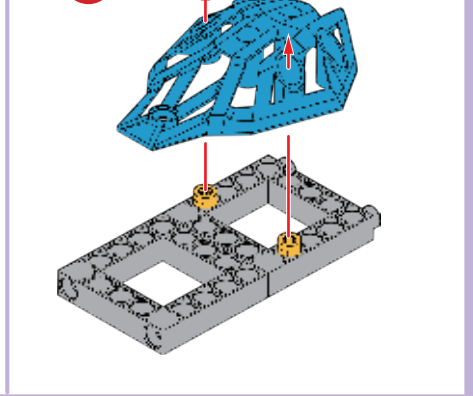
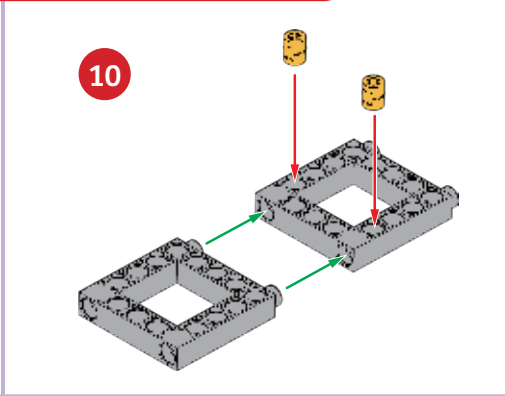
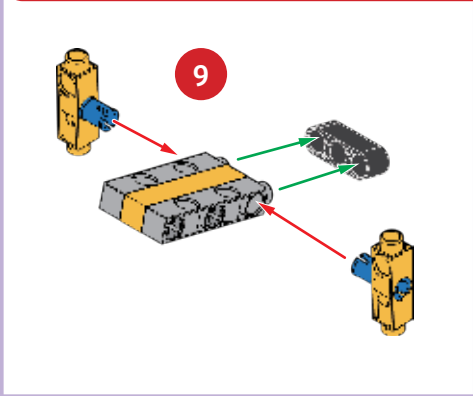

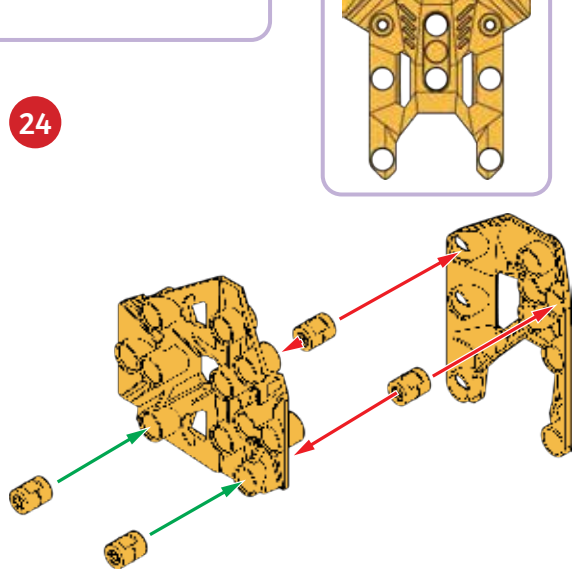
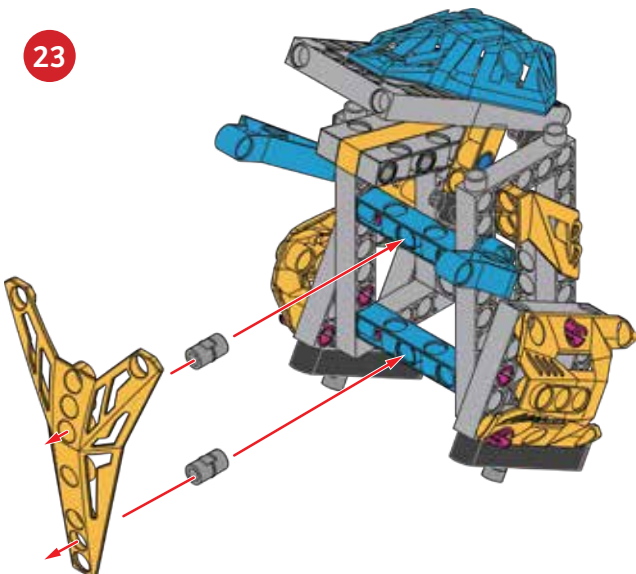
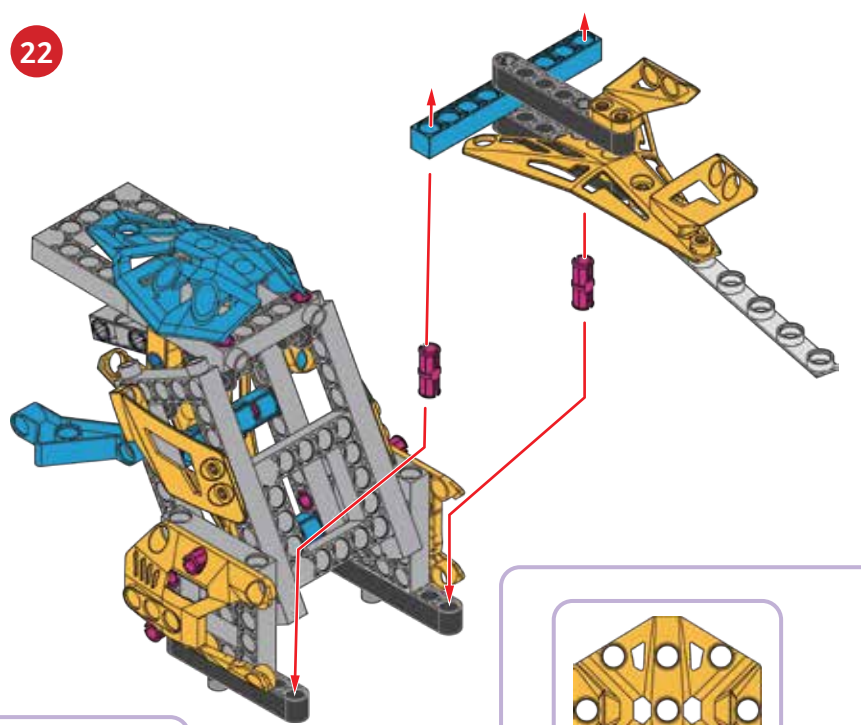
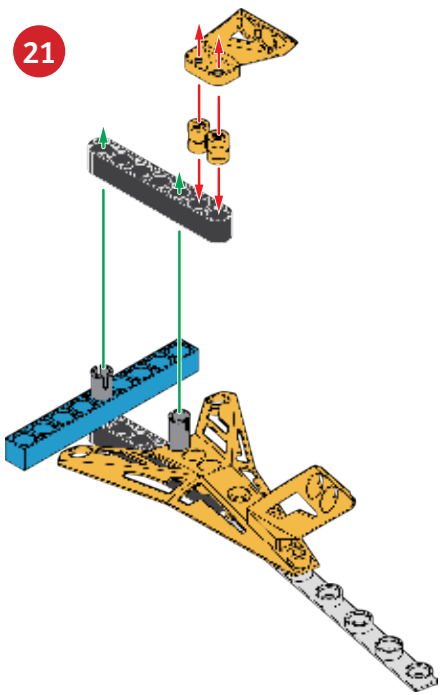
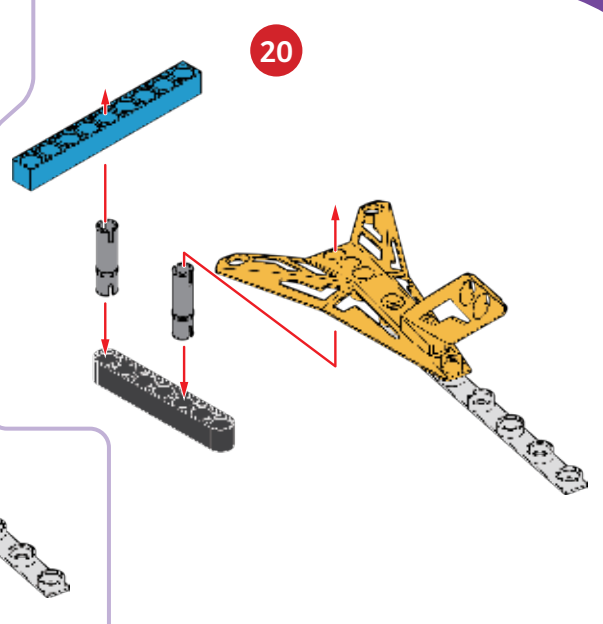
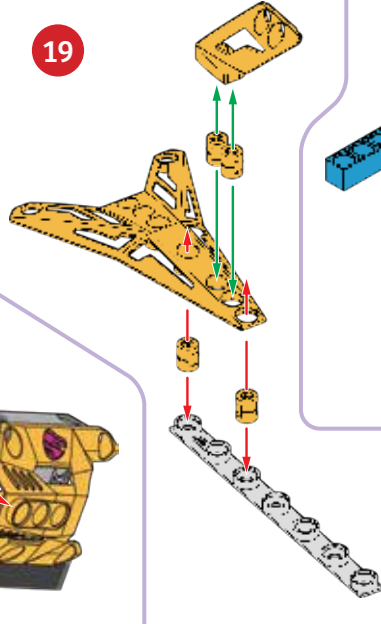
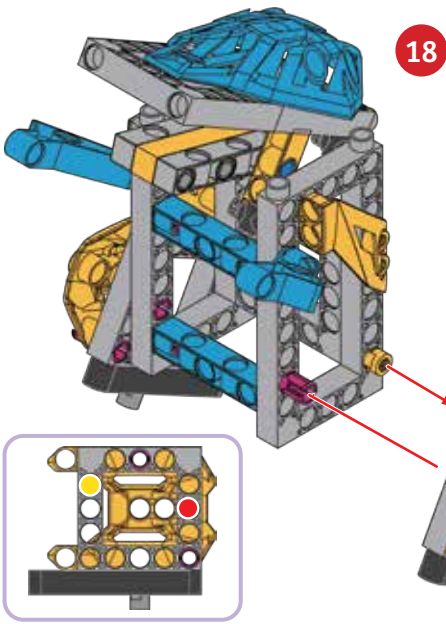



BALANCING DINO ROBOT

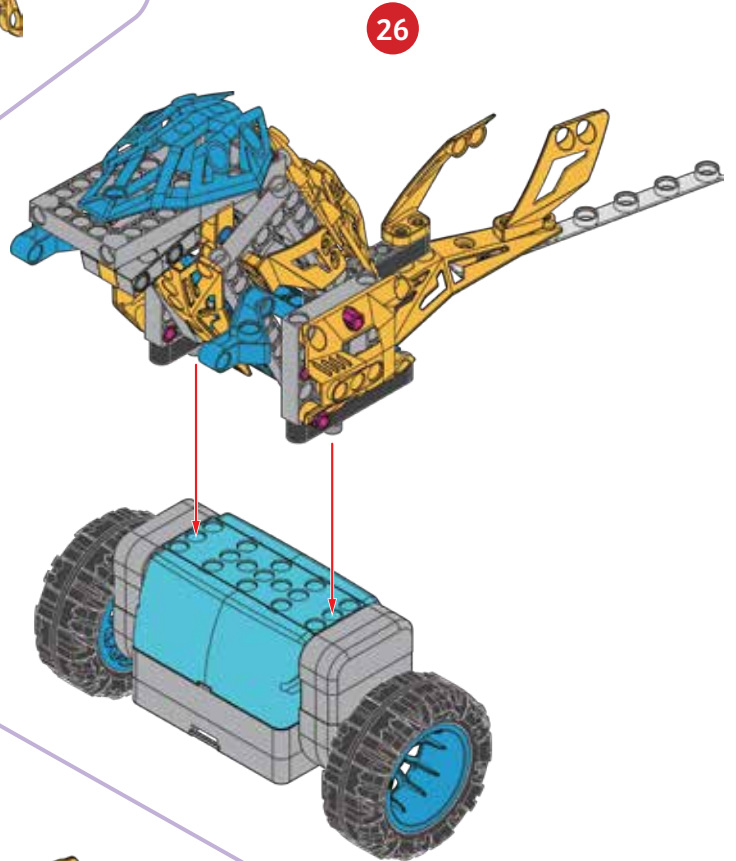
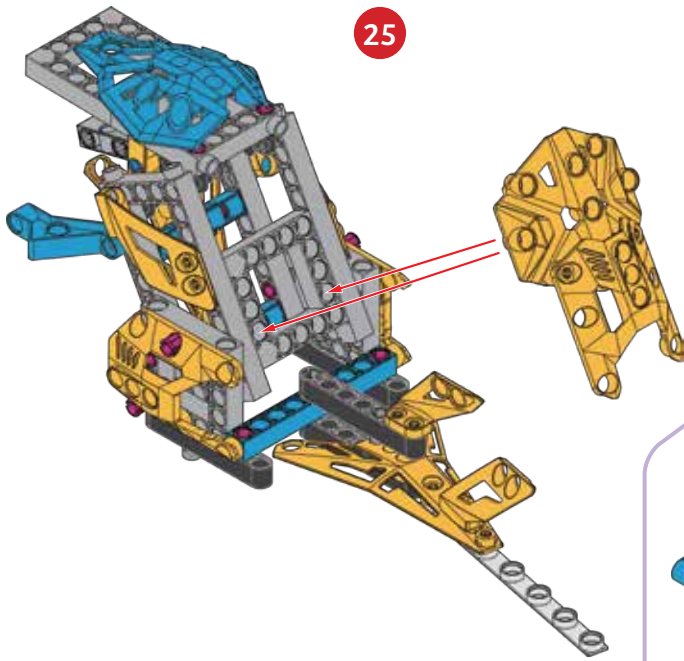

Done!

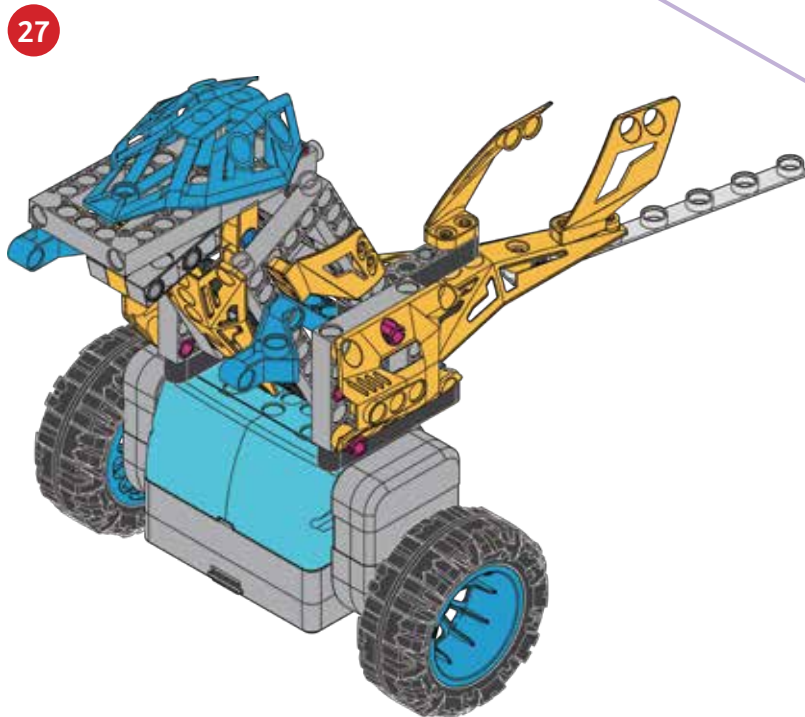

PROGRAMMING



SAMPLE PROGRAM FOR THE BALANCING DINO ROBOT

1. Assemble the model using the instructions on the previous pages. Put the model on the floor in an open area. Hold it upright and turn it on.
2. Establish the Bluetooth connection with the app. Open the **Balancing Dino Robot** program. Note that the balance setting is set to **H**.
3. Press the run button. Hold the model until it is standing upright and balancing on its own. Below, write down what the robot does for each command step of the program.



Balance Setting:

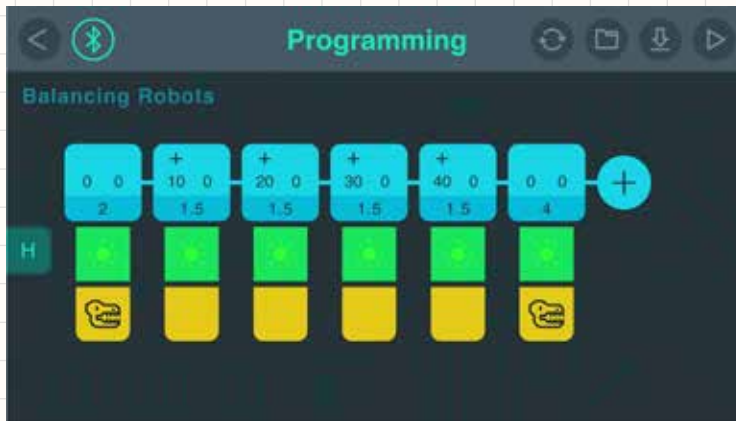

WHAT'S HAPPENING? *Record your observations here.*



CHECK IT OUT



Tyrannosaurus Rex

Tyrannosaurus rex is a type of theropod, which means “beast-footed.” **Theropods are bipedal** — they walk on two legs. Instead of two legs, your balancing dino robot has two wheels!

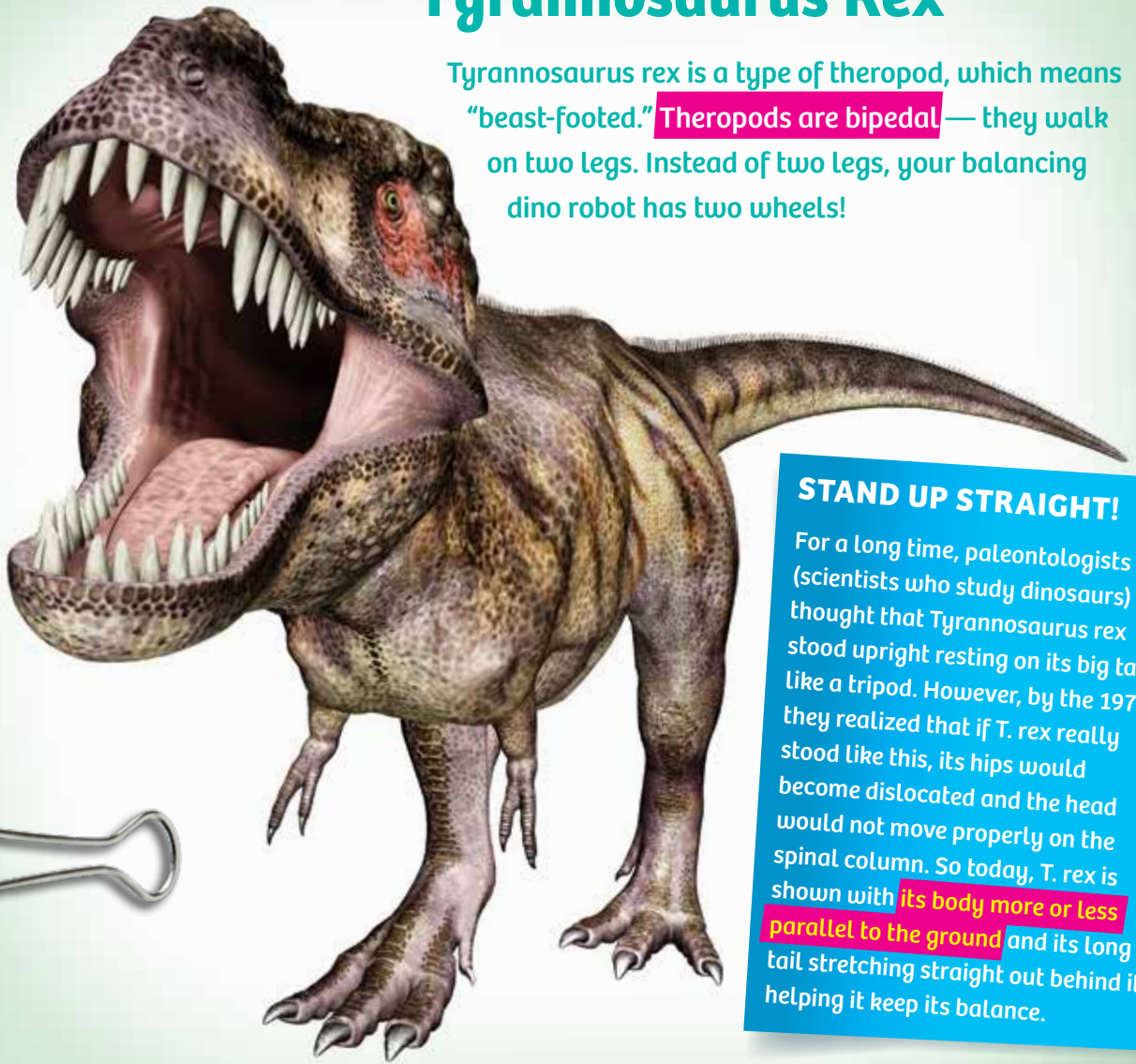

STAND UP STRAIGHT!

For a long time, paleontologists (scientists who study dinosaurs) thought that Tyrannosaurus rex stood upright resting on its big tail like a tripod. However, by the 1970s, they realized that if T. rex really stood like this, its hips would become dislocated and the head would not move properly on the spinal column. So today, T. rex is shown with **its body more or less parallel to the ground** and its long tail stretching straight out behind it, helping it keep its balance.

FOSSILS

Everything we know about dinosaurs comes from what we can infer from studying their fossilized remains and applying what we know about the analogous features of animals that are alive today. Dinosaur skeletons are like huge puzzles with which we are trying to unlock the secrets of these ancient creatures.

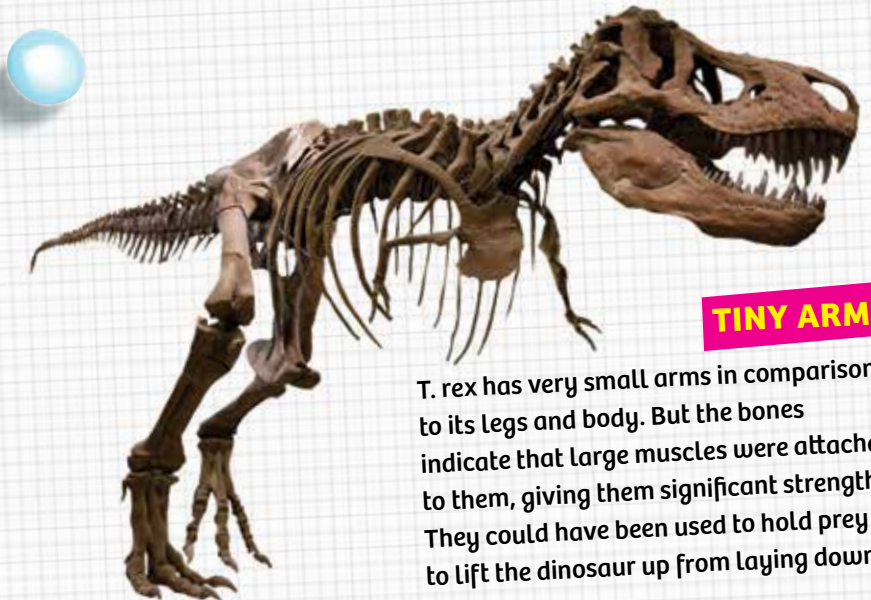

TINY ARMS

T. rex has very small arms in comparison to its legs and body. But the bones indicate that large muscles were attached to them, giving them significant strength. They could have been used to hold prey or to lift the dinosaur up from laying down.

PERSONAL TRANSPORTER

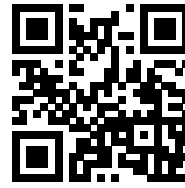

DIGITAL ASSEMBLY INSTRUCTIONS

Scan this QR code to open the product web page. Then, tap the link to access the digital assembly instructions app.

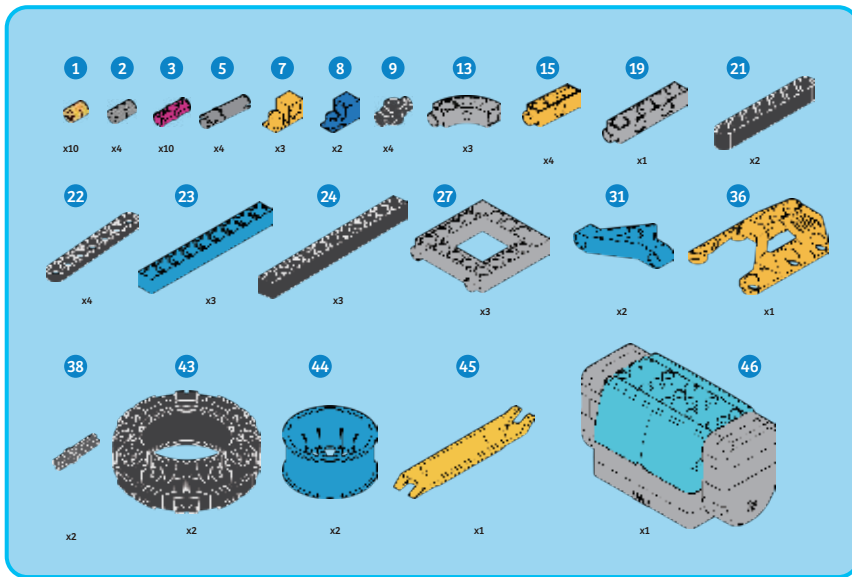

1 A. x2

2 A.

3

4

5

6

7 x2

8 B. x2



PERSONAL TRANSPORTER

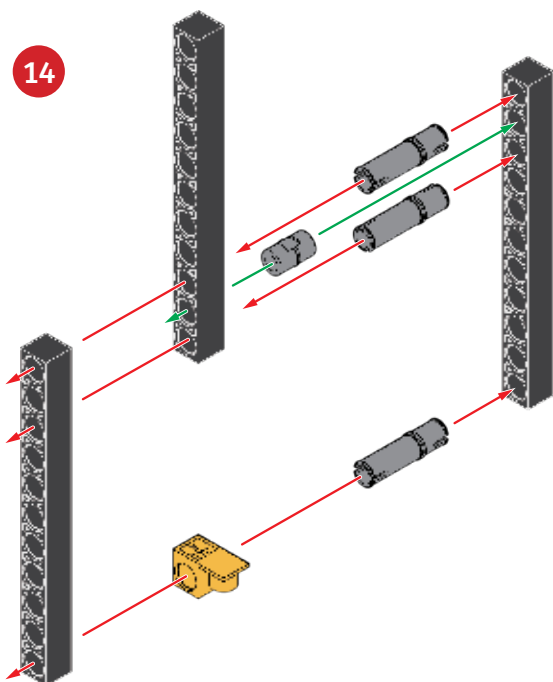
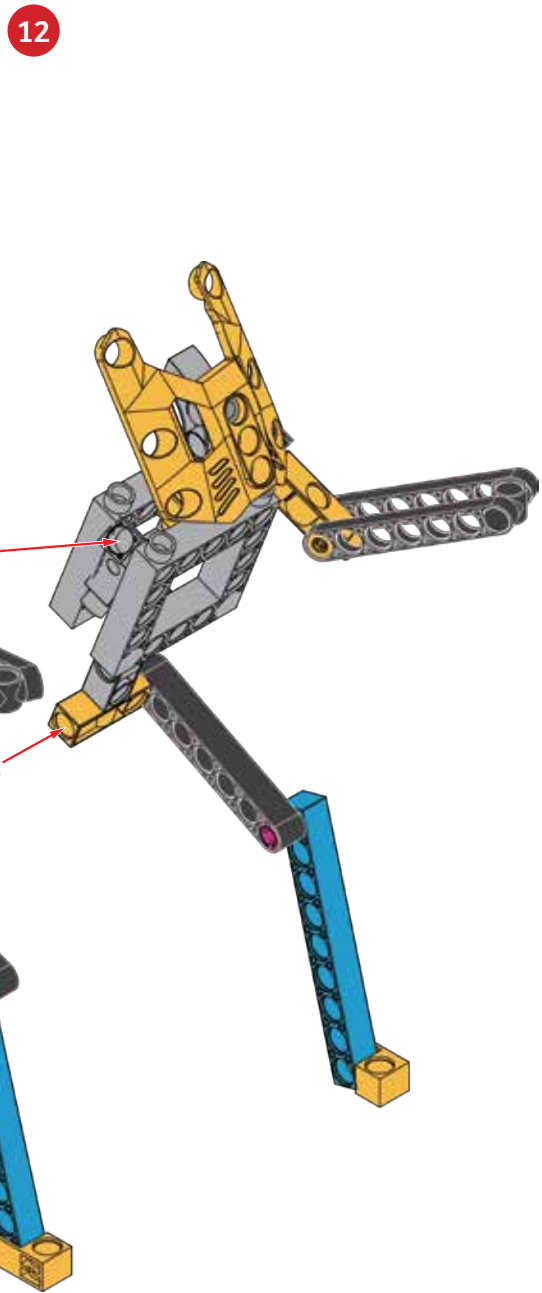
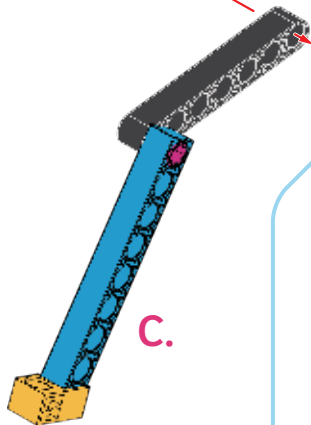
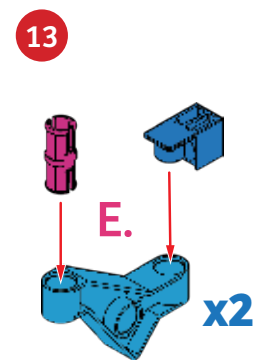
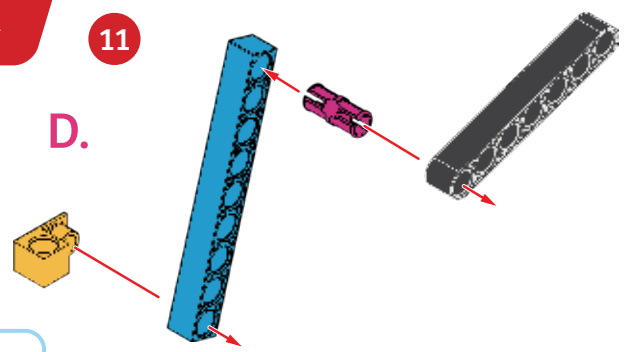
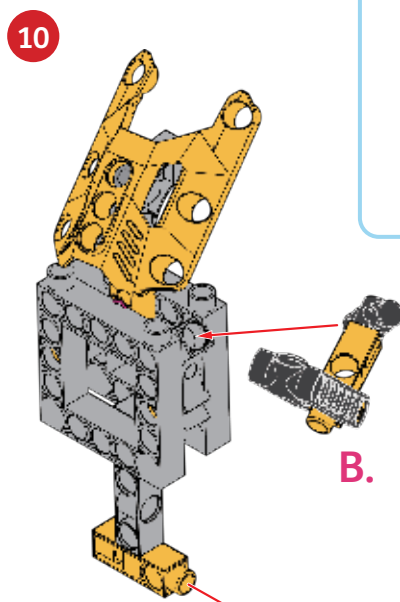
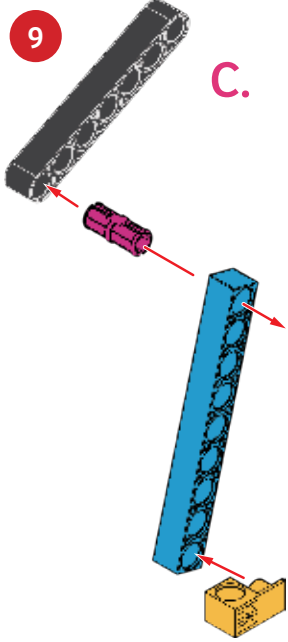

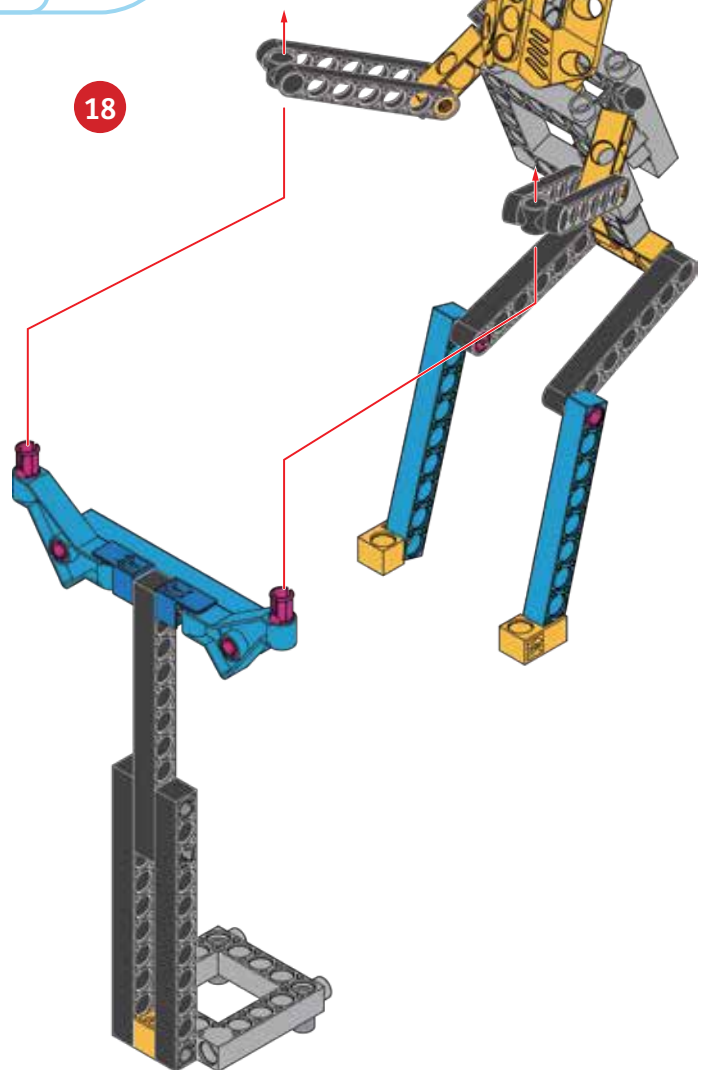
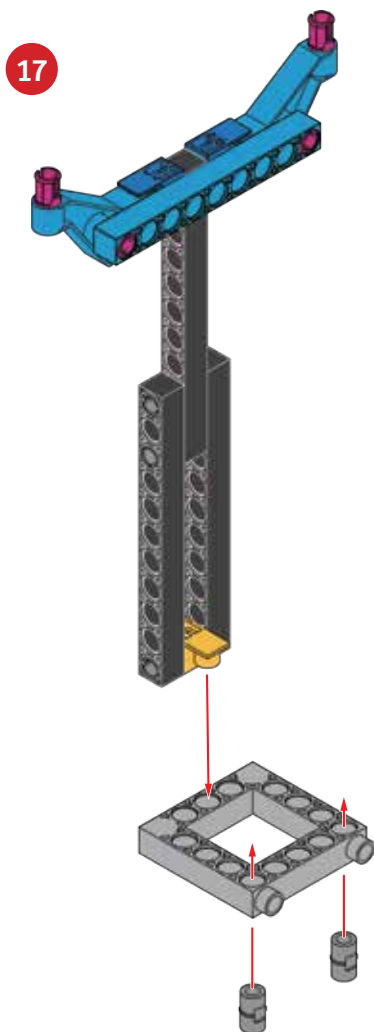
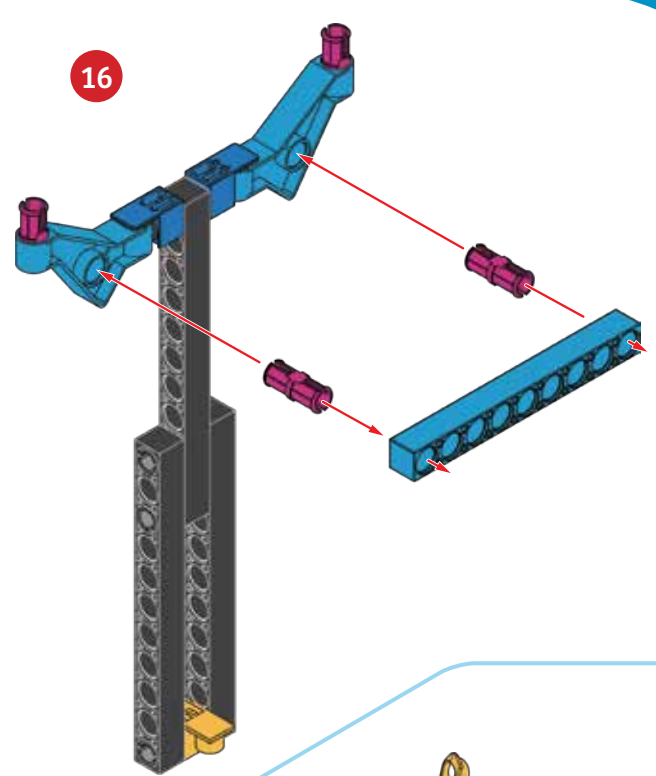
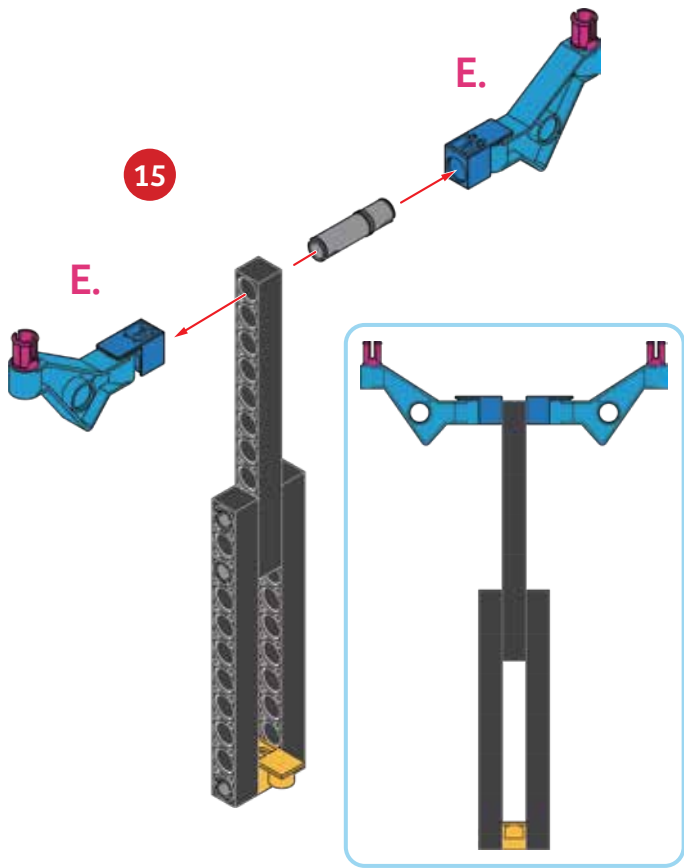



19

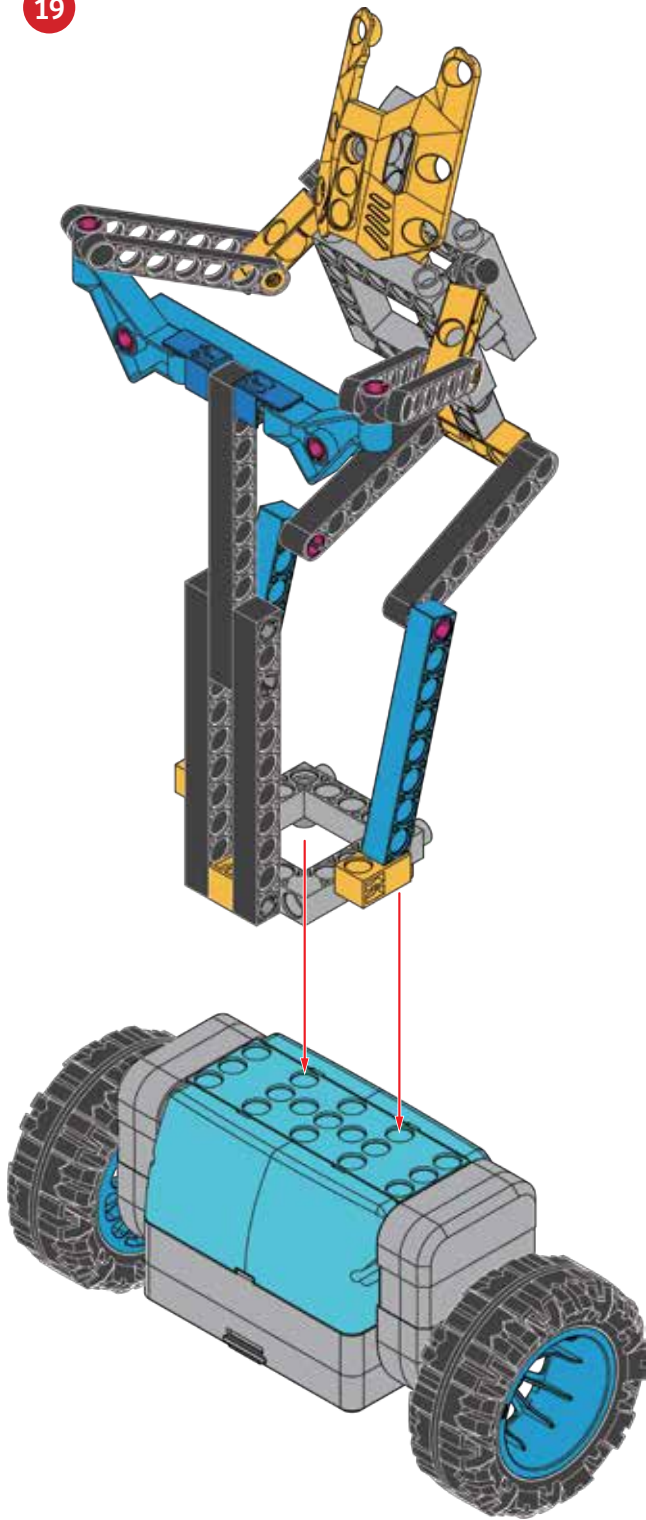

20

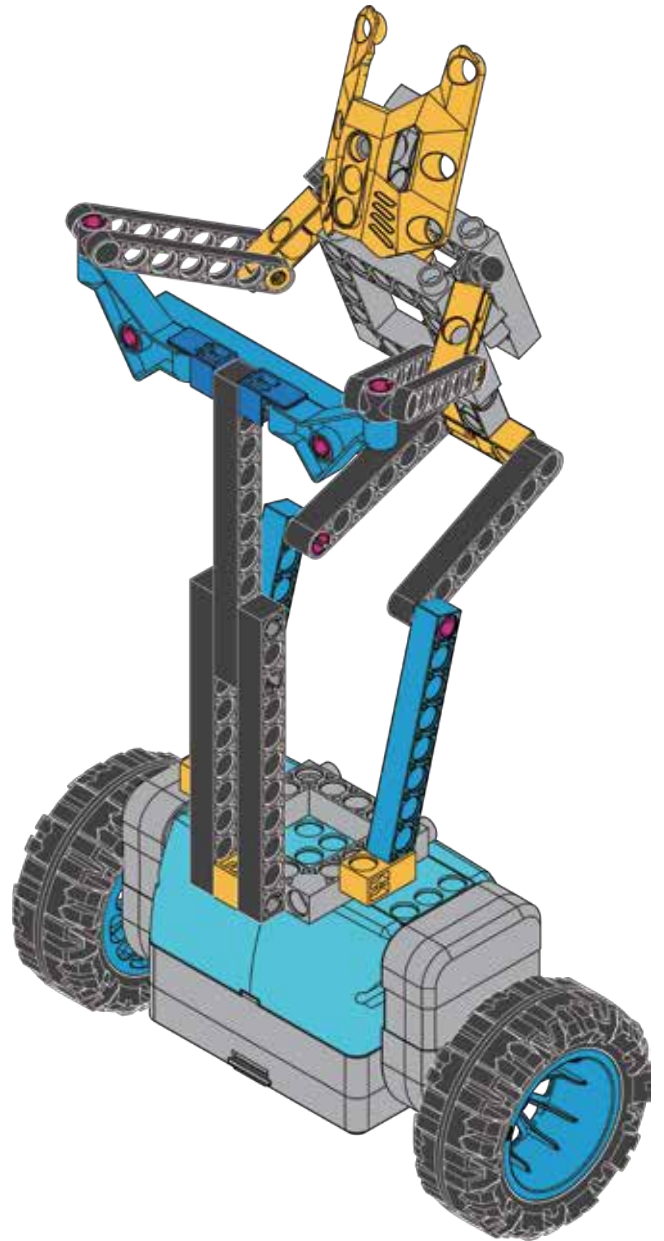

Done!

PROGRAMMING

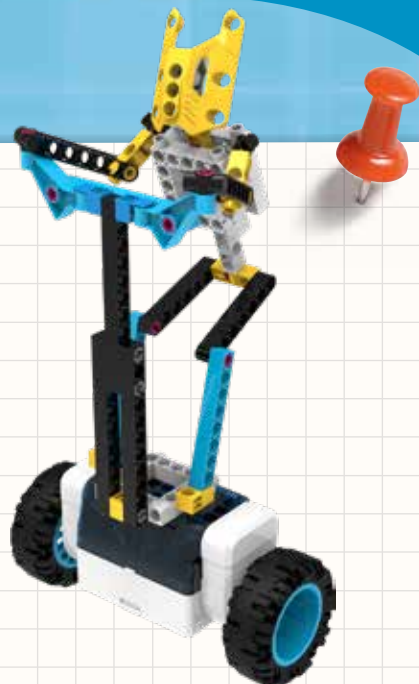

SAMPLE PROGRAM FOR THE PERSONAL TRANSPORTER

1. Assemble the model using the instructions on the previous pages. Put the model on the floor in an open area. Hold it upright and turn it on.
2. Establish the Bluetooth connection with the app. Open the **Personal Transporter** program. Note that the balance setting is set to I.
3. Press the run button. Hold the model until it is standing upright and balancing on its own. Below, write down what the robot does for each command step of the program.
4. Adjust the position of the rider to change its center of gravity. For example, move its legs, arms, or body to be in different positions. Try the program again. Do you notice that the positioning of the rider affects the balancing performance?

Balance Setting:



WHAT'S HAPPENING? Record your observations here.



CHECK IT OUT



Self-Balancing Personal Transporters

The Segway is self-balancing vehicle with two wheels that transports a single person. It was first manufactured in 2001. The rider stands on a platform and holds onto a handlebar used for controlling speed and direction. The Segway works a lot like the balancing robotic base unit in this kit. Tilt sensors and gyroscopic sensors monitor the angle of the Segway, giving feedback telling the motors how to move in order to keep the unit balanced. It is powered by lithium-ion batteries.

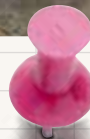



Kosmos Quality and Safety

More than one hundred years of expertise in publishing science experiment kits stand behind every product that bears the Kosmos name. Kosmos experiment kits are designed by an experienced team of specialists and tested with the utmost care during development and production. With regard to product safety, these experiment kits follow European and US safety standards, as well as our own refined proprietary safety guidelines. By working closely with our manufacturing partners and safety testing labs, we are able to control all stages of production. While the majority of our products are made in Germany, all of our products, regardless of origin, follow the same rigid quality standards.

2nd Edition 2019, 2020 Thames & Kosmos, LLC, Providence, RI, USA
Thames & Kosmos® is a registered trademark of Thames & Kosmos, LLC.

This work, including all its parts, is copyright protected. Any use outside the specific limits of the copyright law without the consent of the publisher is prohibited and punishable by law. This applies specifically to reproductions, translations, microfilming, and storage and processing in electronic systems and networks. We do not guarantee that all material in this work is free from copyright or other protection.

Technical product development: Genius Toy Taiwan Co., Ltd., Taichung, Taiwan, R.O.C.
Text and Editing: Ted McGuire
Additional Graphics and Packaging: Dan Freitas

Manual design concept: Atelier Bea Klenk, Berlin
Manual illustrations: Genius Toy Taiwan Co., Ltd., Taichung, Taiwan, R.O.C., and Thames & Kosmos

Manual photos:

© adobestock.com: p. 4 and p. 60 (people of Segways) JackF; p. 4 and 23 (hoverboard rendering) Dzha; p. 23 (people on hoverboards) stacestock; p. 26 (autonomous cars) folienfeuer; p. 26 (car diagram) vegefox.com; p. 30 (pendulum) Andrea Izzotti; p. 36 (balancing bird) antonsov85; p. 42 (robotic waiter) besjunior; p. 42 (warehouse robots) phonlamaiphoto;
© shutterstock.com: p. 42 (delivery drone) Slavoljub Pantelic; p. 48 (balancing robot) Optinik; p. 48 (gyroscope) Gramper;
© istock.com: p. 54 (T. rex); p. 54 (T. rex skeleton)

All other photos: Genius Toy Taiwan Co., Ltd., Taichung, Taiwan, R.O.C., and Thames & Kosmos

The publisher has made every effort to locate the holders of image rights for all of the photos used. If in any individual cases any holders of image rights have not been acknowledged, they are asked to provide evidence to the publisher of their image rights so that they may be paid an image fee in line with the industry standard.

Android, Google Play and the Google Play logo are trademarks of Google Inc. Apple and the Apple logo are trademarks of Apple Inc., registered in the US and other countries. App Store is a service mark of Apple Inc., registered in the US and other countries.

Distributed in North America by Thames & Kosmos, LLC, Providence, RI 02903
Phone: 800-587-2872; Web: www.thamesandkosmos.com

Distributed in United Kingdom by Thames & Kosmos UK, LP, Cranbrook, Kent TN17 3HE
Phone: 01580 713000; Web: www.thamesandkosmos.co.uk

We reserve the right to make technical changes.

Printed in Taiwan / Imprimé en Taiwan

